

iC-WJB

2.7 V LASER DIODE DRIVER



Rev E1, Page 1/12

FEATURES

- ◆ Simple APC adjustment via an external resistor
- ◆ Continuous (CW) or pulsed operation of up to 300 kHz
- ◆ Laser diode current of up to 100 mA
- ◆ Adjustable watchdog for input signals
- ◆ Soft power-on and thermal protection
- ◆ Driver shutdown in case of overtemperature and undervoltage
- ◆ Operation at 2.7 to 6 V with two to four AA/AAA cells
- ◆ Protection against reverse polarity

APPLICATIONS

- ◆ Battery supplied LD modules
- ◆ LD Pointers

PACKAGES

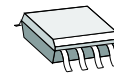

SO8



MSOP8

BLOCK DIAGRAM

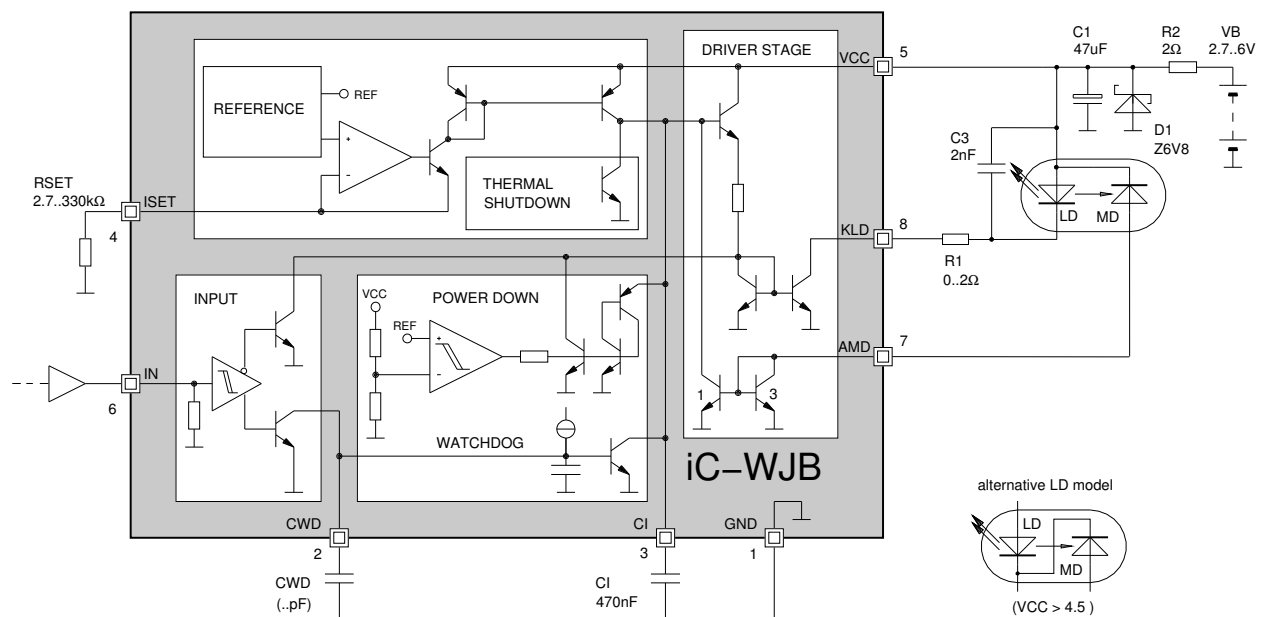

iC-WJB

2.7 V LASER DIODE DRIVER



Rev E1, Page 2/12

DESCRIPTION

The iC-WJB device is a driver IC for laser diodes in continuous or pulsed operation of up to 300 kHz. The wide power supply range of 2.7 to 6 V and the integrated reverse battery protection allows for battery-operation with two to four AA/AAA cells.

The laser diode is activated via switching input IN. A control to the average value of the optical laser power (APC) and integrated protective functions ensure nondestructive operation of the sensitive semiconductor laser.

The IC contains protective diodes to prevent destruction due to ESD, a protective circuit to guard against overtemperature and undervoltage and a soft-start

circuit to protect the laser diode when switching on the power supply. Short-term reversed battery connection destroys neither the IC nor the laser diode.

An external resistor at ISET is employed to adapt the APC to the laser diode being used. The capacitor at CI determines the recovery time constants and the starting time.

A watchdog circuit monitors the switching input IN. If IN remains low longer than preset by the capacitor at CWD, the capacitor of the APC is discharged at pin CI. This ensures that the current through the laser diode during the next high pulse at input IN is not impermissibly high.

PACKAGES SO8, MSOP8 to JEDEC Standard

PIN CONFIGURATION SO8

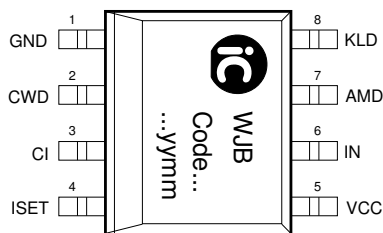

PIN FUNCTIONS

No. Name Function

1	GND	Ground
2	CWD	Capacitor for Watchdog
3	CI	Capacitor for Power Control
4	ISET	Reference Current Input
5	VCC	+2.7 to +6 V Supply Voltage
6	IN	Input
7	AMD	Anode Monitor Diode
8	KLD	Cathode Laser Diode

PIN CONFIGURATION MSOP8

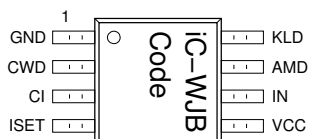

ABSOLUTE MAXIMUM RATINGS

Beyond these values damage may occur; device operation is not guaranteed.

Item No.	Symbol	Parameter	Conditions	Min. / Max.		Unit
				Min.	Max.	
G001	VCC	Supply Voltage VCC		-0.3	6.5	V
G002	VCC	Reverse Voltage at VCC	T < 10 s	-3		V
G003	I(VCC)	Current in VCC	T < 10 s	-500	50	mA
G004	I(CI)	Current in CI		-4	4	mA
G005	V(KLD)	Voltage at KLD	IN = lo	0	9	V
G006	I(KLD)	Current in KLD	IN = hi IN = lo	-4 -4	400 4	mA mA
G007	I(AMD)	Current in AMD		-6	6	mA
G008	I(IN)	Current in IN		-10	2	mA
G009	I(ISET)	Current in ISET		-2	2	mA
G010	I(CWD)	Current in CWD	IN = lo	-2	2	mA
G011	Vd()	ESD Susceptibility at CWD, CI, ISET, IN, AMD, KLD	HBM, 100 pF discharged through 1.5 kΩ		1	kV
G012	Tj	Junction Temperature		-40	150	°C
G013	Ts	Storage Temperature		-40	150	°C

THERMAL DATA

Operating Conditions: VCC = 2.7...6 V

Item No.	Symbol	Parameter	Conditions	Min. / Typ. / Max.			Unit
				Min.	Typ.	Max.	
T01	Ta	Operating Ambient Temperature Range (extended temperature range on request)		-25		90	°C
T02	Rthja	Thermal Resistance Chip to Ambient	surface mounted on PCB, without special cooling			170	K/W

All voltages are referenced to ground unless otherwise stated.

All currents into the device pins are positive; all currents out of the device pins are negative.

ELECTRICAL CHARACTERISTICS

Operating Conditions: VCC = 2.7...6 V, RSET = 2.7...27 kΩ, I(AMD) = 0.15...1.5 mA, Tj = -25...125 °C, unless otherwise noted.

Item No.	Symbol	Parameter	Conditions				Unit
				Min.	Typ.	Max.	
Total Device							
001	VCC	Permissible Supply Voltage Range		2.7		6	V
002	Idc(VCC)	Supply Current in VCC	RSET = 5 kΩ, IN = hi, Idc(KLD) = 40 mA	4	7	13	mA
003	I0(VCC)	Standby Supply Current in VCC	REST = 5 kΩ, IN = lo, Tj = 27 °C		5		mA
004	Iav(VCC)	Supply Current in VCC (average value)	Ipk(KLD) = 80 mA, f(IN) = 200 kHz ±20 %, twhi / twlo = 1		9	15	mA
005	tp(IN-KLD)	Delay Time Pulse Edge V(IN) to I(KLD)	IN(hi ↔ lo), V(50 %) : I(50 %)	65		135	ns
006	Pcon	Power Consumption	VCC = 3 V, V(KLD) ≈ 0.6 V, RSET = 5 kΩ, Idc(KLD) = 40 mA		50		mW
007	Vc(hi)	Clamp Voltage hi at VCC, IN, AMD, KLD, CI, CWD, ISET	I() = 2 mA, other pins open Tj = 27 °C	6.2	7.5	10	V V
Driver							
101	Vs(KLD)	Saturation Voltage at KLD	IN = hi, I(KLD) = 80 mA Tj = 27 °C		0.11	0.3	V V
102	Vs(KLD)	Saturation Voltage at KLD	IN = hi, I(KLD) = 100 mA			0.4	V
103	I0(KLD)	Leakage Current in KLD	IN = lo, V(KLD) = VCC			10	μA
104	V(AMD)	Voltage at AMD	I(AMD) = 1.5 mA Tj = 27 °C	0.4	0.84	1.0	V V
105	tr	Current Rise Time in KLD	I _{max} (KLD) = 20...80 mA, I _p (): 10 → 90 % Tj = 27 °C		30	100	ns ns
106	tf	Current Fall Time in KLD	I _{max} (KLD) = 20...80 mA, I _p (): 90 % → 10 % Tj = 27 °C		20	100	ns ns
107	CR1()	Current Ratio I(AMD)/I(ISET)	I(CI) = 0, closed control loop; RSET = 2.7...27 kΩ RSET = 27...330 kΩ	2.4 2.4	3 3.6	3.8 5.4	
108	CR2()	Current Ratio I(AMD)/I(CI)	V(CI) = 1...2 V, ISET open	2.7	3	3.3	
109	TC1()	Temperature Coefficient of Current Ratio I(AMD)/I(ISET)	I(CI) = 0, closed control loop; RSET = 2.7...27 kΩ RSET = 27...330 kΩ		0.01 -0.1	-0.25	%/°C %/°C
Input IN							
201	Vt(hi)	Threshold hi		45		70	%VCC
202	Vt(lo)	Threshold lo		40		65	%VCC
203	Vt(hys)	Hysteresis	Tj = 27 °C	20	65		mV mV
204	Rin	Pull-Down Resistor	V(IN) = -0.3 V...VCC Tj = 27 °C	4	10	16	kΩ kΩ
205	V0()	Open-loop Voltage	I(IN) = 0			0.1	V
Reference und Thermal Shutdown							
301	V(ISET)	Voltage at ISET	Tj = 27 °C	1.16	1.22	1.28	V V
302	CR()	Current Ratio I(CI)/I(ISET)	V(CI) = 1...2 V, I(AMD) = 0	0.9	1	1.12	
303	RSET	Permissible Resistor at ISET (Control Set-up Range)		2.7		330	kΩ
304	Toff	Thermal Shutdown Threshold		125		150	°C
305	Thys	Thermal Shutdown Hysteresis		10		40	°C
Power-Down and Watchdog							
401	VCCon	Turn-on Threshold VCC	Tj = 27 °C	2.4	2.6	2.7	V V
402	VCCoff	Undervoltage Threshold at VCC	Tj = 27 °C	2.3	2.5	2.63	V V
403	VCChys	Hysteresis	VCChys = VCCon – VCCoff	70	100	150	mV
404	Vs(CI)off	Saturation Voltage at CI with undervoltage	I(CI) = 300 μA, VCC < VCCoff			1.5	V

ELECTRICAL CHARACTERISTICS

Operating Conditions: VCC = 2.7...6 V, RSET = 2.7...27 kΩ, I(AMD) = 0.15...1.5 mA, Tj = -25...125 °C, unless otherwise noted.

Item No.	Symbol	Parameter	Conditions				Unit
				Min.	Typ.	Max.	
405	Vs(CI)wd	Saturation Voltage at CI with IN = lo	I(CI) = 300 μA, t(IN = lo) > tp (*)			1.5	V
406	Isc(CWD)	Pull-Up Current at CWD	V(CWD) = 0, IN = lo	2		15	μA
407	tpmin	Min. Activation Time for Watchdog	IN = lo, CWD open Tj = 27 °C	10	25	45	μs μs
408	Kwd (*)	Constant for Calculating the Watchdog Activation Time	IN = lo Tj = 27 °C	0.19	0.25	0.57	μs/pF μs/pF

(*) $tp = (C(CWD) * Kwd) + tpmin$ (see Applications Information)

APPLICATIONS INFORMATION

Laser Power Adjustment

The iC-WJB device can be adapted to CW laser diodes of up to 40 mW. When the supply voltage is higher than approx. 4.5 V, LD models in common cathode configuration can be used.

The pin ISET is used for the adjustment to the sensitivity of the monitor diode and to set the desired optical laser power. The setpoint for the averaging control of the monitor diode current is pre-set at this pin.

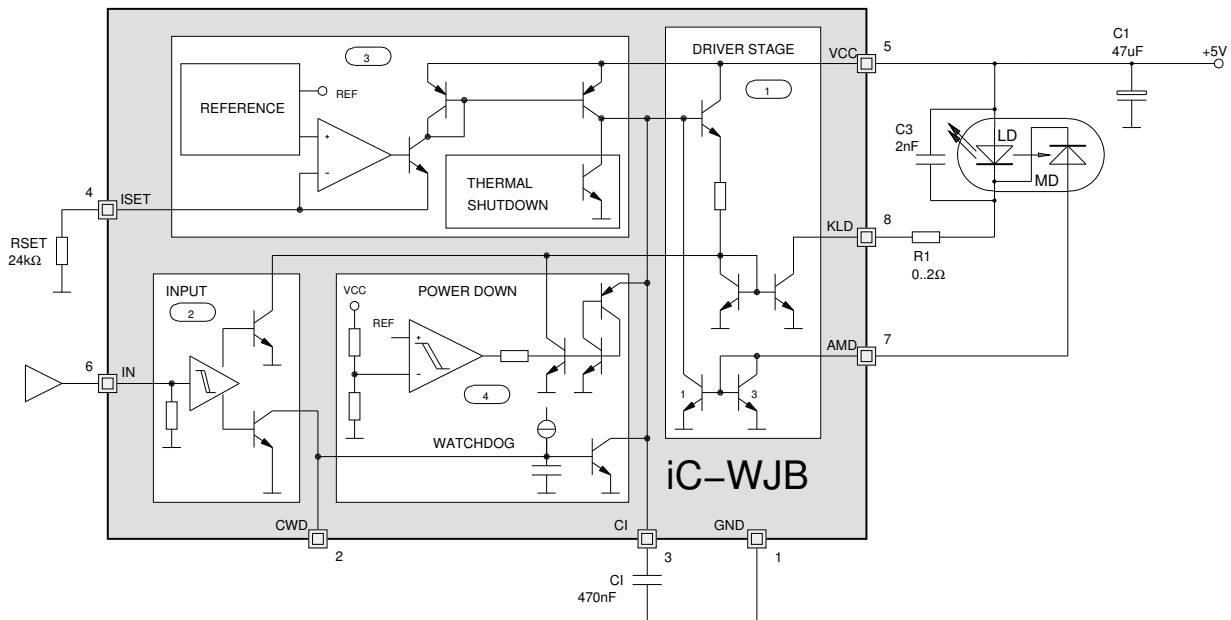

Figure 1: Circuit diagram for LD models with a common cathode

To calculate the current required at ISET, the average optical laser power is to determine:

$$P_{av} = P_{peak} * \frac{t_{whi}}{T}$$

with peak value P_{peak} and pulse/period duration t_{whi}/T .

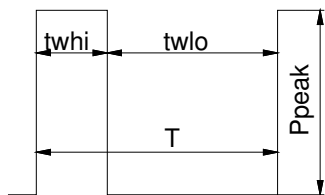

Figure 2: Duty cycle

Example for CW operation

$P_{CW} = 1 \text{ mW}$ (pin IN at VCC, pin CWD open), laser diode maximum optical output of 3 mW, monitor diode with 0.75 mA at 3 mW.

At $P_{av} = P_{CW} = 1 \text{ mW}$, the monitor diode current is 0.25 mA and RSET is calculated to:

$$RSET = \frac{CR1 * V(ISET)}{I_{av}(AMD)} = \frac{3 * 1.22 \text{ V}}{0.25 \text{ mA}} = 14.64 \text{ k}\Omega$$

with Electrical Characteristics No. 301 for $V(ISET)$ and No. 107 for current ratio CR1.

Example for pulse operation

Pulse duty factor t_{whi}/T set to 20% at $P_{peak} = 3 \text{ mW}$, laser diode as above with maximum optical output of 3 mW, monitor diode with 0.75 mA at 3 mW.

The average optical power is set to 0.6 mW by the pulse duty factor; the average monitor diode current I_{AV} is then 0.15 mA. The resistor RSET is calculated to:

$$RSET = \frac{CR1 * V(ISET)}{I_{av}(AMD)} = \frac{3 * 1.22 V}{0.15 mA} = 24.4 k\Omega$$

with the Electrical Characteristics No. 301 for $V(ISET)$ and No. 108 for current ratio CR1.

Averaging control (APC)

The control of the average optical laser power requires a capacitor at pin CI. This capacitor is used for averaging and must be adjusted to the selected pulse repetition frequency and the charging current preset with RSET. The ratios are linear in both cases, i.e. the capacitor CI must be increased in size proportionally as the pulse repetition frequency slows or the current from ISET increases:

$$CI \geq \frac{440 * I(ISET)}{f * V(ISET)} = \frac{440}{f * RSET}$$

Example

Pulse repetition frequency 100 kHz, RSET = 10 kΩ:
CI = 440 nF, chosen 470 nF.

Otherwise the charging of the capacitor CI during the pulse pauses (with $I(ISET) = 1.22 V / RSET$) will create an excessive average value potential and may destroy the laser diode during the next pulse. The capacitor CI is correctly dimensioned when the current through the laser diode and the optical output signal do not show any overshots following the rising edge.

In steady-state condition and for a pulse duty factor of 50 % (pulse / pause = 1:1), wave forms as shown in Figure 3.

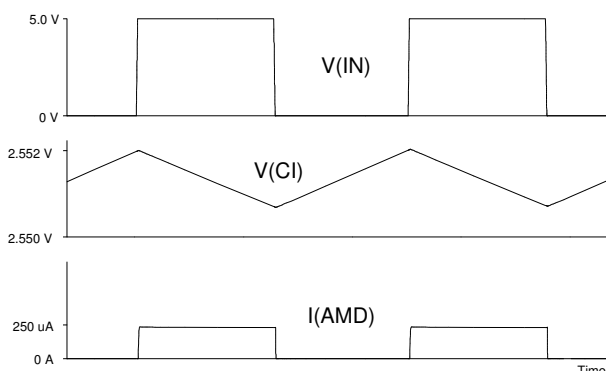

Figure 3: Steady-state APC, $f(IN) = 100 kHz$ (1:1), CI = 470 nF, RSET = 10 kΩ

Figure 4 shows the corresponding signals for a pulse duty factor of 20%. The influence of the pulse duty

factor on the peak value of the monitor current proportional to the laser current is apparent. The average kept constant by the control (RSET unchanged) means a peak value increased by the factor 2.5. The pulse duty factor for which RSET was dimensioned should therefore be kept constant if possible.

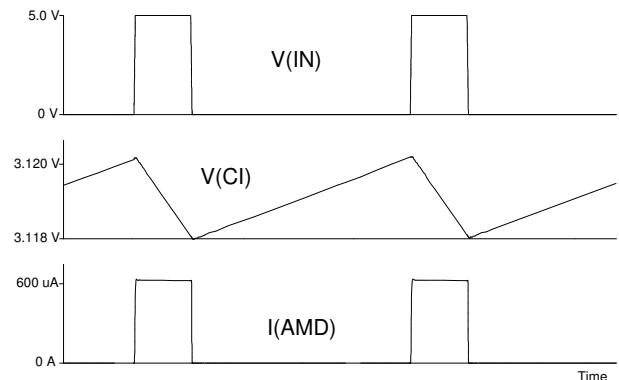

Figure 4: Steady-state APC, $f(IN) = 100 kHz$ (1:4), CI = 470 nF, RSET = 10 kΩ

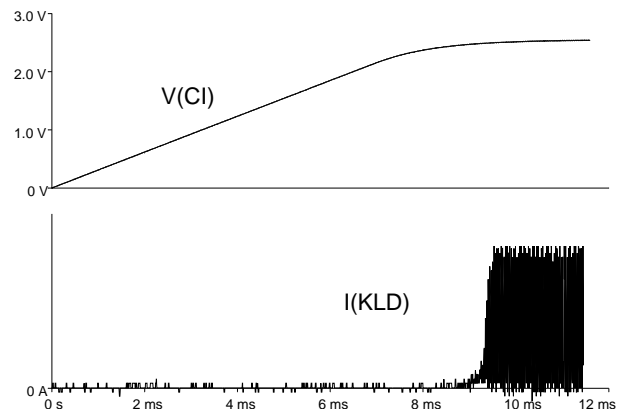

Figure 5: Turn-on behaviour, $f(IN) = 100 kHz$ (1:1), CI = 470 nF, RSET = 10 kΩ

Turn-on and turn-off behaviour

Capacitor CI also determines the starting time from switching on the supply voltage VCC to steady-state laser pulse operation or after a discharge of CI by the watchdog. The following applies to estimating the starting time (Figure 5):

$$T_{on} \approx \frac{1.7 V * CI}{I(ISET)} = \frac{1.7 V * CI * RSET}{1.22 V}$$

Example

CI = 470 nF, RSET = 10 kΩ: $T_{on} \approx 6.5 ms$

Figure 6 shows a detailed view of the start of laser operation; Figure 7 shows the shut-down behaviour. The decline in the voltage at CI and the absence of the

laser pulses indicate that the undervoltage detector is active.

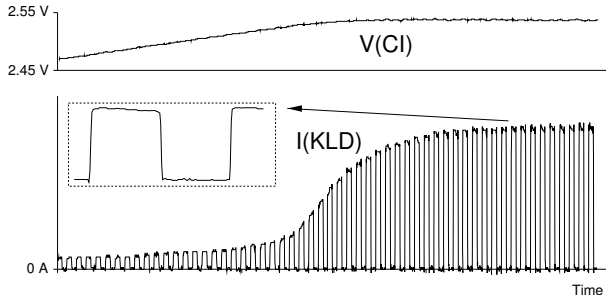

Figure 6: Turn-on behaviour, detailed view $f(IN) = 100 \text{ kHz}$ (1:1), $CI = 470 \text{ nF}$, $RSET = 10 \text{ k}\Omega$

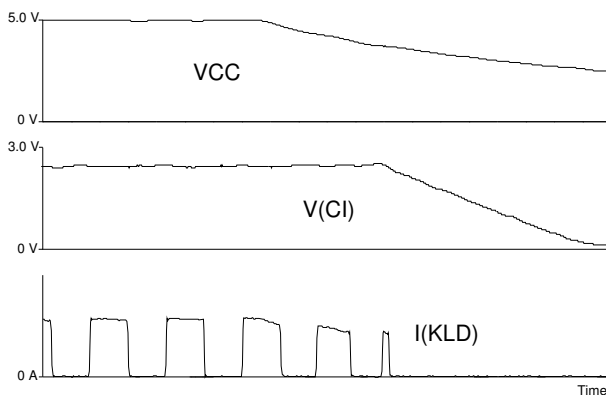

Figure 7: Turn-off behaviour, $f(IN) = 100 \text{ kHz}$ (1:1), $CI = 470 \text{ nF}$, $RSET = 10 \text{ k}\Omega$

Watchdog

The watchdog ensures that the capacitor CI is discharged during protracted pulses at IN . During the pulse pauses the voltage at CI increases by ΔV (Figure 3).

$$\Delta V = \frac{I(ISET) * t_{wlo}}{CI}$$

The discharge of capacitor CI by the watchdog protects the laser diode from being destroyed by an excessive turn-on current during the next pulse.

The capacitor CWD should be dimensioned such that the response time t_p of the watchdog is slightly longer than the pulse pause t_{wlo} of the input signal. As a result, the watchdog is just short of being activated.

For response times t_p longer than t_{pmin} applies:

$$CWD = \frac{t_p - t_{pmin}}{K_{wd}}$$

with t_{pmin} and K_{wd} from Electrical Characteristics No. 407, 408.

Figure 8 shows the signals during normal operation, without the watchdog being activated. The potential at CWD rises during pulse pauses but does not reach the watchdog activation threshold.

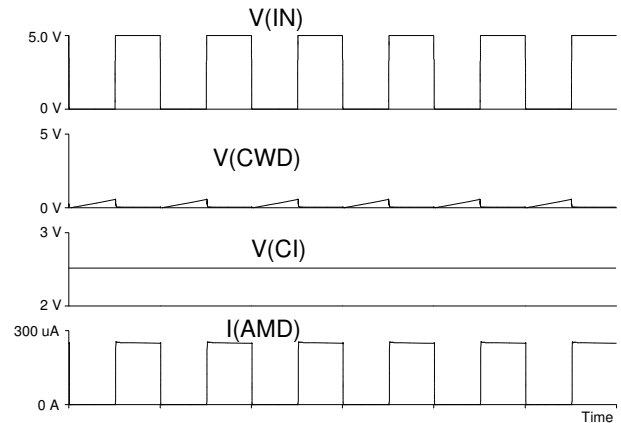

Figure 8: Watchdog, CWD open, $f(IN) = 100 \text{ kHz}$ (1:1), $CI = 470 \text{ nF}$, $RSET = 10 \text{ k}\Omega$

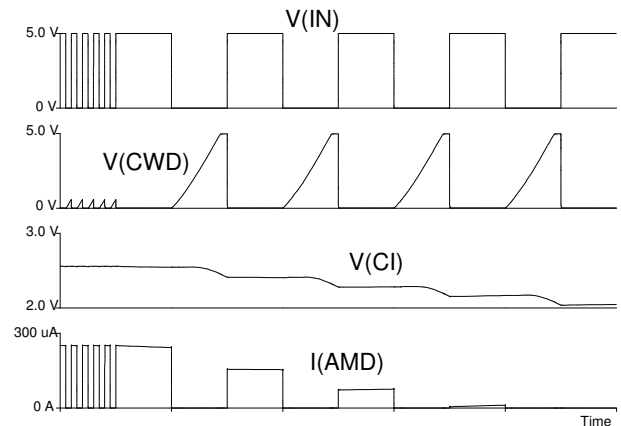

Figure 9: Watchdog, CWD open, $f(IN) = 100 \text{ kHz} \rightarrow 10 \text{ kHz}$ (1:1), $CI = 470 \text{ nF}$, $RSET = 10 \text{ k}\Omega$

Figure 9 shows the watchdog behaviour when the input frequency is reduced from 100 kHz to 10 kHz . The pulse pauses are longer than the watchdog's response time. The watchdog begins to discharge the capacitor CI current limited. The remaining charge time during the pulse pauses before further watchdog intervention is not sufficient to maintain the initial potential at CI . The potential is thus gradually reduced until it reaches the saturation voltage $Vs(CI)_{wd}$ (Electrical Characteristics No. 405).

The watchdog therefore protects the laser diode from destruction when the input signal change in such a manner that the capacitor CI is not longer adequate for averaging.

Furthermore, the introduction of the watchdog permits long pulse pauses and activation of the laser diode with pulse packets.

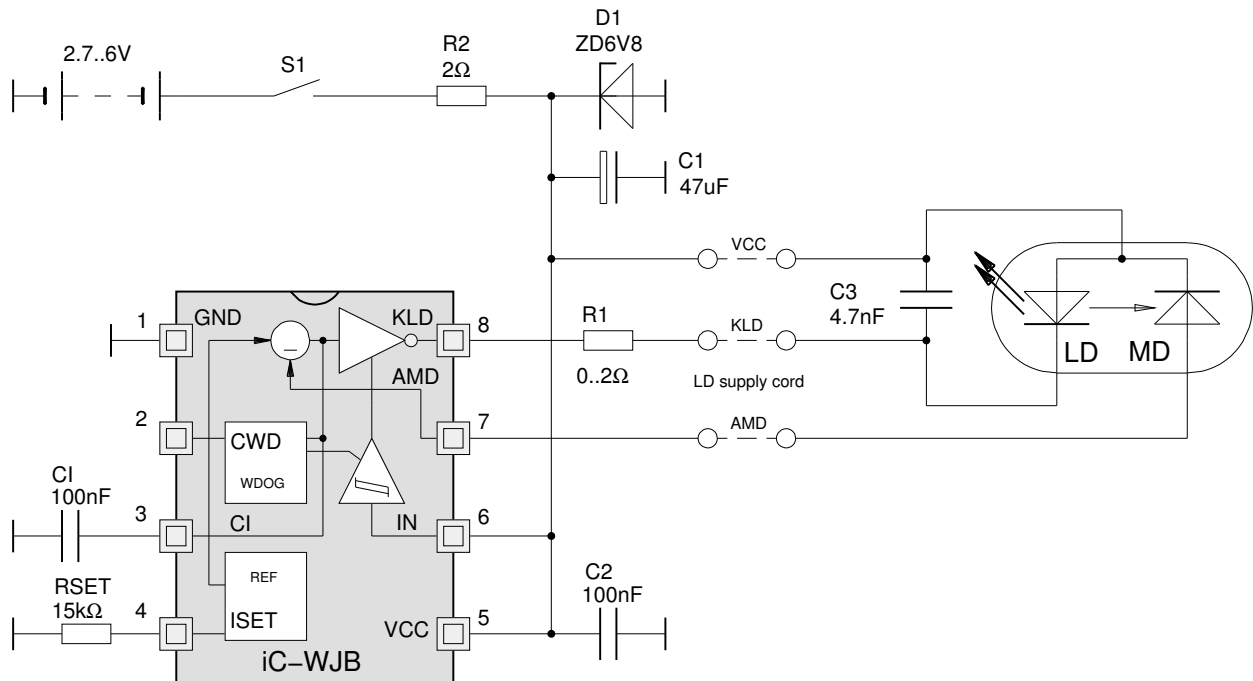

Figure 10: CW operation via cable plus protective circuitry

CW Operation

In case of CW operation, the input IN can be connected to the power supply VCC. The pin CWD may be left open, because the capacitor for the watchdog is not necessary. The capacitor CI for the averaging control can be reduced to 100 nF.

Operation of laser diode via cable

It is recommended to connect a capacitor of 1 to 10 nF across the laser diode in order to protect the laser diode against destruction due to ESD or transients. This capacitor should be placed close to the laser diode and not at the beginning of the LD supply line.

An approx. 2 Ω series resistor at pin KLD reduces the IC power consumption and damps possible reso-

nances of the load circuit caused by the inductive LD supply line. This resistor is useful for many applications, also for those which do not operate via cable.

On a PCB the forward path VCC to the laser diode should be arranged in parallel with the return path to KLD even when the line is only a few centimeters in length.

Additional protective components for clipping of strong positive and negative spikes can be useful, in particular when contact bouncing occurs in an inductive accumulator power supply line. Elements which come into question here are D1 and R1 as in Figure 10.

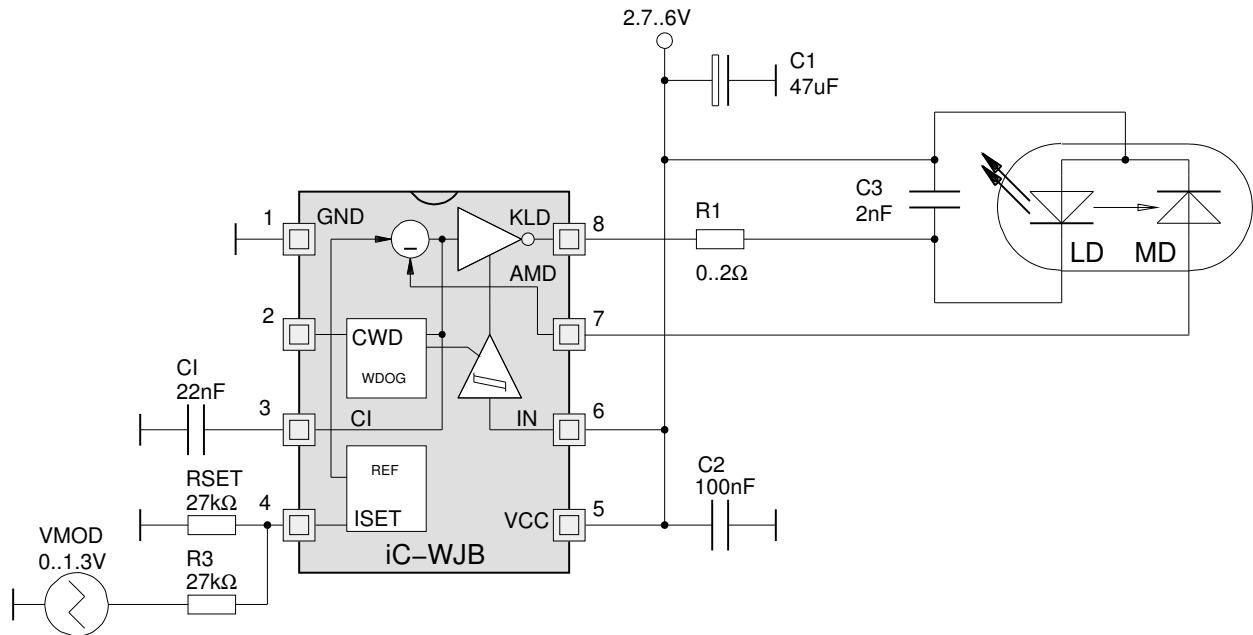

Figure 11: Analogue modulation during CW operation

Analogue modulation during CW operation

The modulation cut-off frequency is determined by the capacitor $C1$ as well as by the operating point set with the resistor $RSET$. With $C1 = 100\text{ nF}$ and $RSET = R3 = 15\text{ k}\Omega$ the cut-off frequency is approx. 30 kHz, with $C1 = 22\text{ nF}$ and the same resistor value of about 150 kHz.

The laser power can also be modulated by adapting a current source, e.g. by using an operational amplifier with a current output (OTA). To limit the current at pin

$ISET$ while turning on the power supply for the OTA circuitry, however, $RSET$ should be connected to the OTA output (instead of to GND). The maximum current possible at $ISET$ must be taken into consideration when dimensioning the capacitor $C1$.

PC board layout

The ground connections of the external components $C1$, CWD and $RSET$ have to be directly connected at the IC with the GND terminal.

DEMO BOARD

For the devices iC-WJ/WJZ/WJB a Demo Board is available for test purpose. The following figures show

the schematic diagram and the component side of the test PCB.

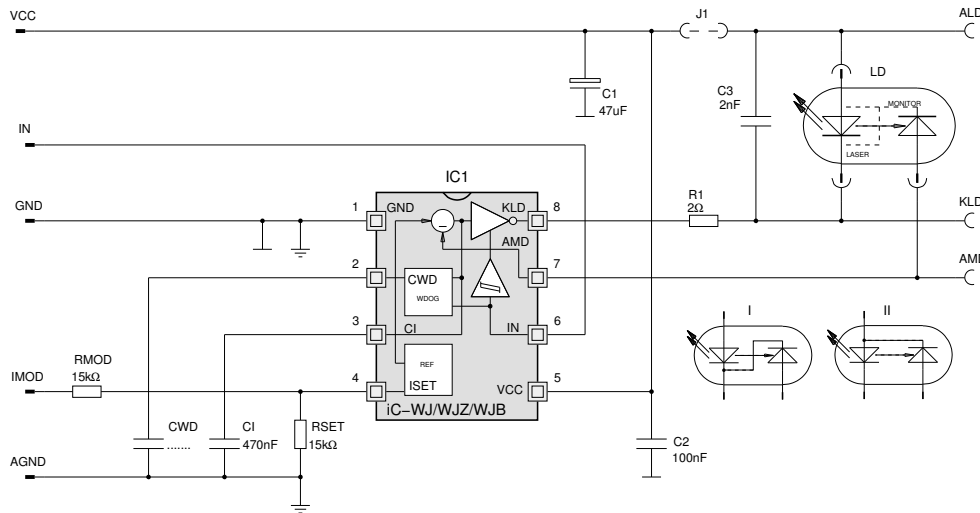

Figure 12: Schematic diagram of the Demo Board

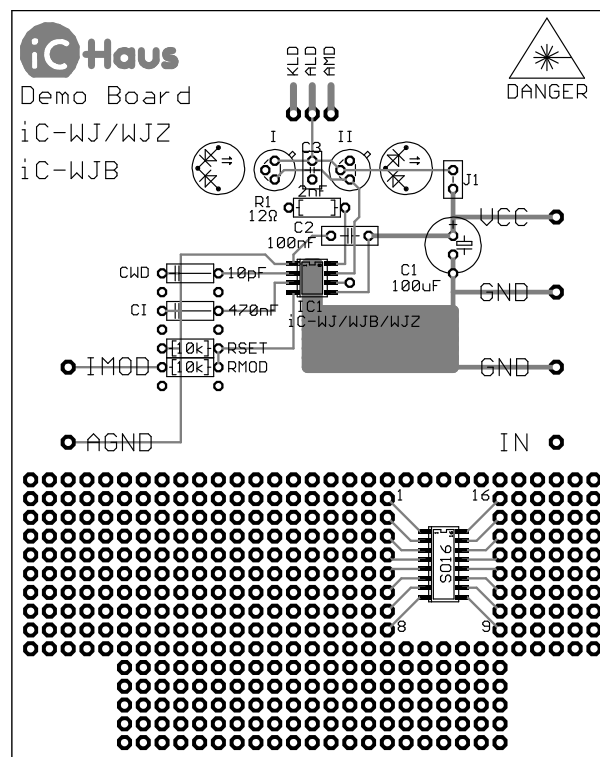

Figure 13: Demo Board (components side)

This specification is for a newly developed product. iC-Haus therefore reserves the right to change or update, without notice, any information contained herein, design and specification; and to discontinue or limit production or distribution of any product versions. Please contact iC-Haus to ascertain the current data. Copying – even as an excerpt – is only permitted with iC-Haus approval in writing and precise reference to source.

iC-Haus does not warrant the accuracy, completeness or timeliness of the specification on this site and does not assume liability for any errors or omissions in the materials. The data specified is intended solely for the purpose of product description. No representations or warranties, either express or implied, of merchantability, fitness for a particular purpose or of any other nature are made hereunder with respect to information/specification or the products to which information refers and no guarantee with respect to compliance to the intended use is given. In particular, this also applies to the stated possible applications or areas of applications of the product.

iC-Haus conveys no patent, copyright, mask work right or other trade mark right to this product. iC-Haus assumes no liability for any patent and/or other trade mark rights of a third party resulting from processing or handling of the product and/or any other use of the product.

As a general rule our developments, IPs, principle circuitry and range of Integrated Circuits are suitable and specifically designed for appropriate use in technical applications, such as in devices, systems and any kind of technical equipment, in so far as they do not infringe existing patent rights. In principle the range of use is limitless in a technical sense and refers to the products listed in the inventory of goods compiled for the 2008 and following export trade statistics issued annually by the Bureau of Statistics in Wiesbaden, for example, or to any product in the product catalogue published for the 2007 and following exhibitions in Hanover (Hannover-Messe).

We understand suitable application of our published designs to be state-of-the-art technology which can no longer be classed as inventive under the stipulations of patent law. Our explicit application notes are to be treated only as mere examples of the many possible and extremely advantageous uses our products can be put to.

iC-WJB

2.7 V LASER DIODE DRIVER



Rev E1, Page 12/12

ORDERING INFORMATION

Type	Package	Order Designation
iC-WJB	SO8	iC-WJB SO8
WJB Evaluation Board	MSOP8	iC-WJB MSOP8 iC-WJB EVAL WJ1D

For technical support, information about prices and terms of delivery please contact:

iC-Haus GmbH
Am Kuemmerling 18
D-55294 Bodenheim
GERMANY

Tel.: +49 (61 35) 92 92-0
Fax: +49 (61 35) 92 92-192
Web: <http://www.ichaus.com>
E-Mail: sales@ichaus.com

Appointed local distributors: http://www.ichaus.de/support_distributors.php