

iC-TW9 *Moskito*

16 BIT ABZ QUADRATURE COUNTER

FEATURES

- 16 bit counter easily extendable to any width using μ C software
- 100 MHz counter at 5 V supply
- 2-wire, 3-wire, 4-wire SPI
- Two programmable set-points
- Power supply voltage of 1.7 V to 5 V operation
- 5 V tolerant ABZ inputs for any supply voltage
- 3 mm x 3 mm QFN16
- $<1 \mu\text{A}$ power consumption with no ABZ input activity
- Extended temperature range of -40 to $+125 \text{ }^\circ\text{C}$

APPLICATIONS

- Flexible incremental control applications
- Linear and rotary encoder applications

PACKAGES

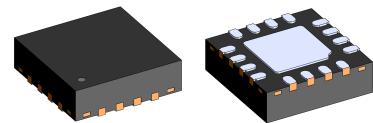

QFN16 3x3

BLOCK DIAGRAM

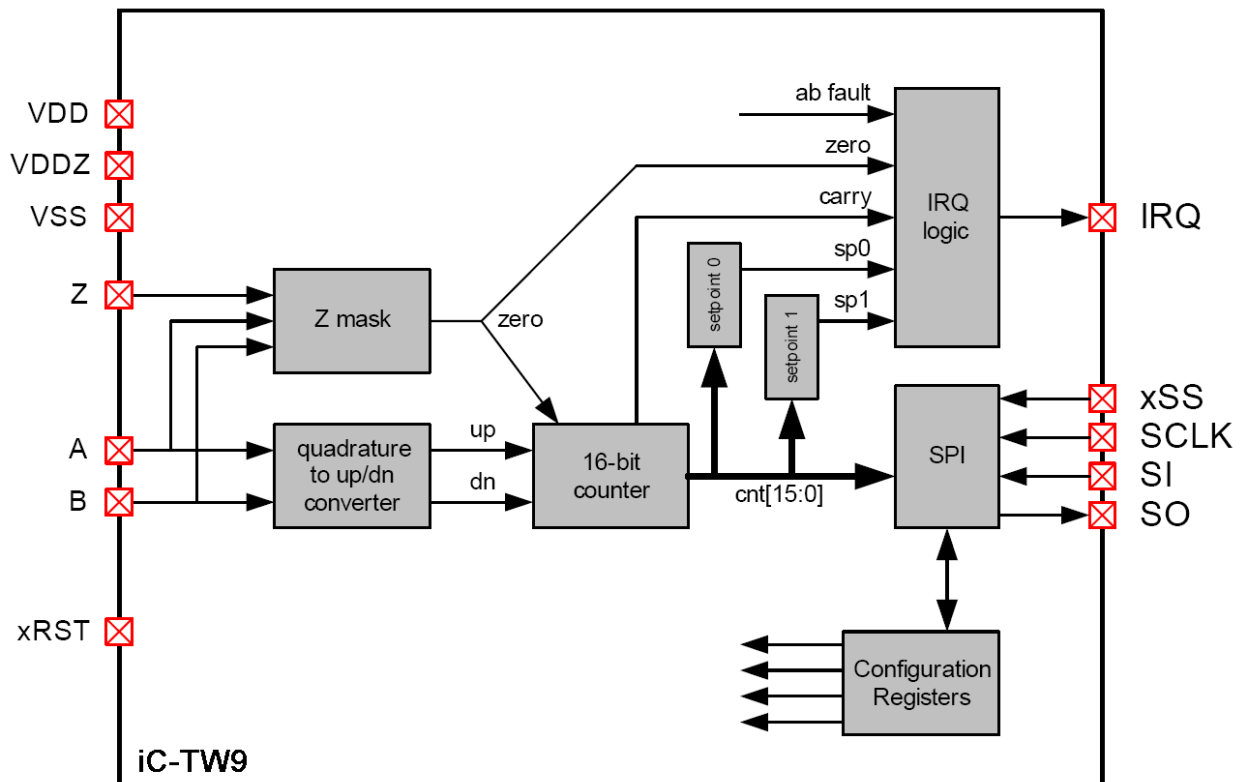

iC-TW9 *Moskito*

16 BIT ABZ QUADRATURE COUNTER

preliminary



Rev A0.5, Page 2/4

DESCRIPTION

The Mosquito Chip iC-TW9 is an up to 100MHz quadrature ABZ counter with an SPI back-end interface. The counter is 16-bit wide but it can be easily extended to arbitrary length by software.

The iC-TW9 implements an automatic sleep mode, only consuming power when actively counting. Its power consumption is directly proportional to the ABZ input activity and goes down to less than 1 μ A with no activity.

The iC-TW9 also provides several IRQ sources, therefore relieving the controlling μ C from constantly needing to poll the device. Once a condition triggers an IRQ, the μ C can read-out the iC-TW9 status and react accordingly.

Two set-points can be programmed to trigger an IRQ when reached by the 16-bit counter.

iC-TW9 Moskito

16 BIT ABZ QUADRATURE COUNTER

preliminary



Rev A0.5, Page 3/4

PACKAGES

PIN CONFIGURATION QFN16 3 mm x 3 mm

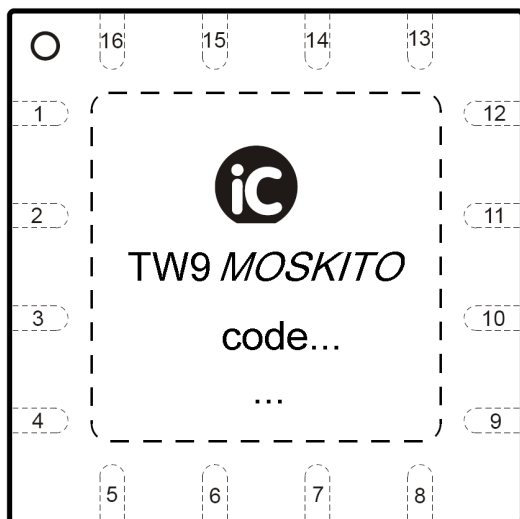

PIN FUNCTIONS

No. Name Function

1	xRST	External Reset Input (active low, I)
2	IRQ	IRQ Interrupt Request Output (O)
3	xSS	SPI Slave Select (I)
4	nc	not connected
5	SO	SPI Data Out (O)
6	SI	SPI Data In (I)
7	SCLK	SPI Slave Clock Input (I)
8	nc	not connected
9	nc	not connected
10	DVSS	Ground GND
11	ZAP	ZAP needs to be tied to DVDD
12	DVDD	1.7 V to 5.5 V Supply DVDD
13	PINA	A Signal Input (I)
14	PINB	B Signal Input (I)
15	PINZ	Z Signal Input (I)
16	nc	not connected
TP	GND	Thermal Pad (bottom side)

The *Thermal Pad* of the QFN package (bottom side) is to be connected to a ground plane on the PCB which must have GND potential.

Function: I = input, O = output, B = bidirectional.

Only pin 1 marking on top or bottom defines the package orientation (iC-TW9 MOSKITO label and coding is subject to change).

iC-Haus expressly reserves the right to change its products and/or specifications. An info letter gives details as to any amendments and additions made to the relevant current specifications on our internet website www.ichaus.de/infoletter; this letter is generated automatically and shall be sent to registered users by email.

Copying – even as an excerpt – is only permitted with iC-Haus' approval in writing and precise reference to source.

iC-Haus does not warrant the accuracy, completeness or timeliness of the specification and does not assume liability for any errors or omissions in these materials.

The data specified is intended solely for the purpose of product description. No representations or warranties, either express or implied, of merchantability, fitness for a particular purpose or of any other nature are made hereunder with respect to information/specification or the products to which information refers and no guarantee with respect to compliance to the intended use is given. In particular, this also applies to the stated possible applications or areas of applications of the product.

iC-Haus conveys no patent, copyright, mask work right or other trade mark right to this product. iC-Haus assumes no liability for any patent and/or other trade mark rights of a third party resulting from processing or handling of the product and/or any other use of the product.

As a general rule our developments, IPs, principle circuitry and range of Integrated Circuits are suitable and specifically designed for appropriate use in technical applications, such as in devices, systems and any kind of technical equipment, in so far as they do not infringe existing patent rights. In principle the range of use is limitless in a technical sense and refers to the products listed in the inventory of goods compiled for the 2008 and following export trade statistics issued annually by the Bureau of Statistics in Wiesbaden, for example, or to any product in the product catalogue published for the 2007 and following exhibitions in Hanover (Hannover-Messe).

We understand suitable application of our published designs to be state-of-the-art technology which can no longer be classed as inventive under the stipulations of patent law. Our explicit application notes are to be treated only as mere examples of the many possible and extremely advantageous uses our products can be put to.

iC-TW9 *Moskito*

16 BIT ABZ QUADRATURE COUNTER

preliminary



Rev A0.5, Page 4/4

ORDERING INFORMATION

Type	Package	Order Designation
iC-TW9 Evaluation Board	QFN16, 3 mm x 3 mm PCB, 100 mm x 80 mm	iC-TW9 QFN16 iC-TW9 EVAL TW9_1D

For technical support, information about prices and terms of delivery please contact:

iC-Haus GmbH
Am Kuemmerling 18
D-55294 Bodenheim
GERMANY

Tel.: +49 (61 35) 92 92-0
Fax: +49 (61 35) 92 92-192
Web: <http://www.ichaus.com>
E-Mail: sales@ichaus.com

Appointed local distributors: http://www.ichaus.com/sales_partners