

# MU2S 30-32N

## iC-MU MAGNETIC TARGET DESCRIPTION

### ORDERING INFORMATION

Type	Order Destination	Description/Options
Magnetic target	MU2S 30-32N	2-Track nonius encoder disc, axial magnetization Number of pole pairs: master 32, nonius 31 Diameter 30 mm, for 10 mm shaft (press fit) Carrier material: Aluminium

### CODE DISC DIMENSIONS

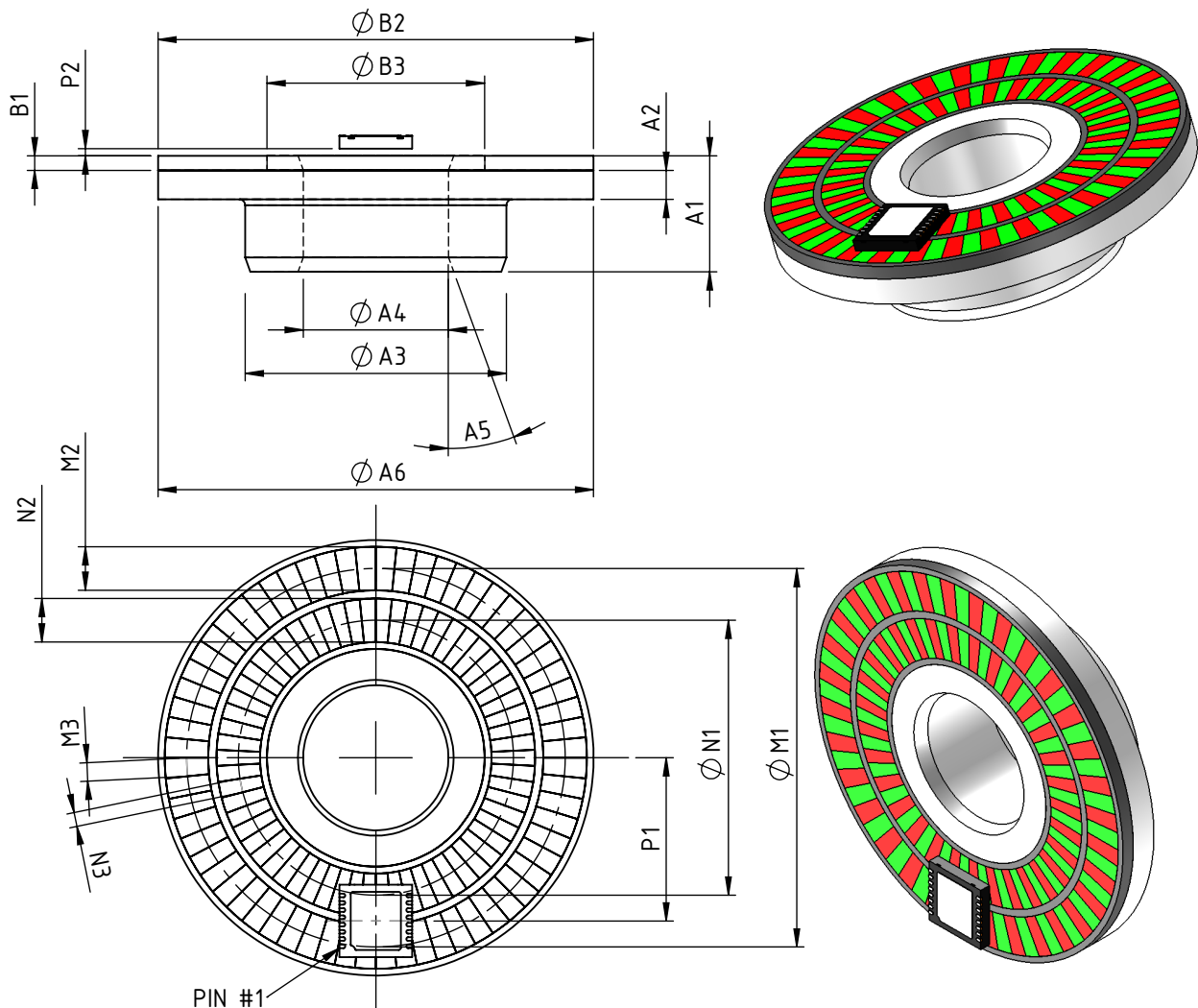

drc\_mu2s\_pack2, 2-1

#### Notice: Interference in function

External magnetic fields change the functional properties. Magnetic fields of  $\geq 1$  mT reduce system accuracy, magnetic fields of  $\geq 30$  mT can damage the disc magnetization. The functionality of the system may no longer be ensured. Direct contact with magnetic clamps or other permanent magnets must be avoided.

# MU2S 30-32N

## iC-MU MAGNETIC TARGET DESCRIPTION

preliminary



Rev A3, Page 2/3

### ABSOLUTE MAXIMUM RATINGS

Beyond these values damage may occur; device operation is not guaranteed.

Item No.	Symbol	Parameter	Conditions			Unit
				Min.	Max.	
G001	Bext	Maximum External Magnetic Field Strength		-20	20	mT

### THERMAL DATA

Operation conditions: No changes of the magnetic characteristics

Item No.	Symbol	Parameter	Conditions				Unit
				Min.	Typ.	Max.	
T01	Ta	Operating Ambient Temperature Range		-40		95	°C

### DIMENSION TABLE

Carrier tolerances according to DIN ISO 2768-f unless otherwise specified

Item No.	Parameter	Comments	Min.	Typ.	Max.	Tolerance	Unit
<b>Physical Dimensions Carrier</b>							
A1	Total Height			8.0		± 0.1	mm
A2	Height of Carrier Plate			2.0			mm
A3	Diameter of Shaft			18.0		r6	mm
A4	Diameter of Bore Hole			10.0		M6	mm
A5	Chamfer			20°x1			mm
A6	Diameter of Carrier Plate			30.0			mm
<b>Physical Dimensions Magnetic Coating</b>							
B1	Thickness of Magnetic Material			1.0			mm
B2	Outer Diameter of Magnetic Material			29.0			mm
B3	Inner Diameter of Magnetic Material			12.0			mm
<b>Magnetic Dimensions Outer Track (Master)</b>							
M1	Diameter of Master Track	referred to axial center		26.08			mm
M2	Width of Master Track			2.5			mm
M3	Pole Width of Master Track	referred to track center		1.28			mm
<b>Magnetic Dimensions Inner Track (Nonius)</b>							
N1	Diameter of Nonius Track	referred to axial center		18.88			mm
N2	Width of Nonius Track			2.5			mm
N3	Pole Width of Nonius Track	referred to track center		0.96			mm
<b>Chip Position</b>							
P1	Radial Position of Chip Center	referred to axial center		11.24			mm
P2	Distance Package Surface DFN16-5x5	referred to magnetic coating surface		0.4			mm
P3	Distance Sensor Surface (Bare Die)	referred to magnetic coating surface		0.8			mm
P4	Rotation of Chip	vs. outer magnetic track		0.0			deg
<b>Magnetic Material Characteristics</b>							
Hc	Coercive Field Strength	at 20 °C		170			kA/m
Br	Remanence	at 20 °C		240			mT
TKB	Temperature Coefficient of the Remanence	temperature range -40 °C...95 °C		-0.2			%/K
Bpp	Magnetic Field Amplitude	at 0.8 mm effective distance (sensor to magnetic surface )	20				mT

# MU2S 30-32N

## iC-MU MAGNETIC TARGET DESCRIPTION

preliminary



Rev A3, Page 3/3

### REVISION HISTORY

Rel	Rel.Date	Chapter	Modification	Page
A1	12-09-29		Initial Releases	

Rel	Rel.Date	Chapter	Modification	Page
A2	14-04-11	CODE DISC DIMENSIONS	Drawing update, added Notice	1,2

Rel	Rel.Date	Chapter	Modification	Page
A3	14-09-26	DIMENSION TABLE	Item A1: Added tolerance	2

iC-Haus expressly reserves the right to change its products and/or specifications. An info letter gives details as to any amendments and additions made to the relevant current specifications on our internet website [www.ichaus.de/infoletter](http://www.ichaus.de/infoletter); this letter is generated automatically and shall be sent to registered users by email.

Copying – even as an excerpt – is only permitted with iC-Haus' approval in writing and precise reference to source.

iC-Haus does not warrant the accuracy, completeness or timeliness of the specification and does not assume liability for any errors or omissions in these materials.

The data specified is intended solely for the purpose of product description. No representations or warranties, either express or implied, of merchantability, fitness for a particular purpose or of any other nature are made hereunder with respect to information/specification or the products to which information refers and no guarantee with respect to compliance to the intended use is given. In particular, this also applies to the stated possible applications or areas of applications of the product.

iC-Haus products are not designed for and must not be used in connection with any applications where the failure of such products would reasonably be expected to result in significant personal injury or death (*Safety-Critical Applications*) without iC-Haus' specific written consent. Safety-Critical Applications include, without limitation, life support devices and systems. iC-Haus products are not designed nor intended for use in military or aerospace applications or environments or in automotive applications unless specifically designated for such use by iC-Haus.

iC-Haus conveys no patent, copyright, mask work right or other trade mark right to this product. iC-Haus assumes no liability for any patent and/or other trade mark rights of a third party resulting from processing or handling of the product and/or any other use of the product.