

iC-LQ

PULSE AND AC LIGHT SENSOR



Rev B2, Page Page 1/7

FEATURES

- ◆ Fast response amplifier with on-chip photodiode
- ◆ High interference immunity due to monolithic design
- ◆ Active photodiode area of 1 mm²
- ◆ Suitable for visible and near infrared light
- ◆ Integrated band-pass filter with 150 kHz center frequency
- ◆ Maximum gain obtained for pulse light of 1.2 μs and upwards
- ◆ Excellent low frequency and ambient light suppression
- ◆ Transfer characteristics irrespective of ambient light level
- ◆ Soft signal and noise limiter on excessive light conditions
- ◆ Fast recovery on flash light
- ◆ Analog current source output; transimpedance can be set by external resistor
- ◆ Low power consumption from single 5 to 12 V supply also at high ambient light levels
- ◆ Options: TO metal can packages, optoBGA packages, customised COB versions

APPLICATIONS

- ◆ Amplification of pulse and AC light signals
- ◆ Receiver for through beam, reflex and proximity sensors

CHIP

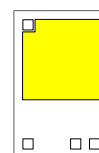

chip size 1.2 mm × 1.88 mm

BLOCK DIAGRAM

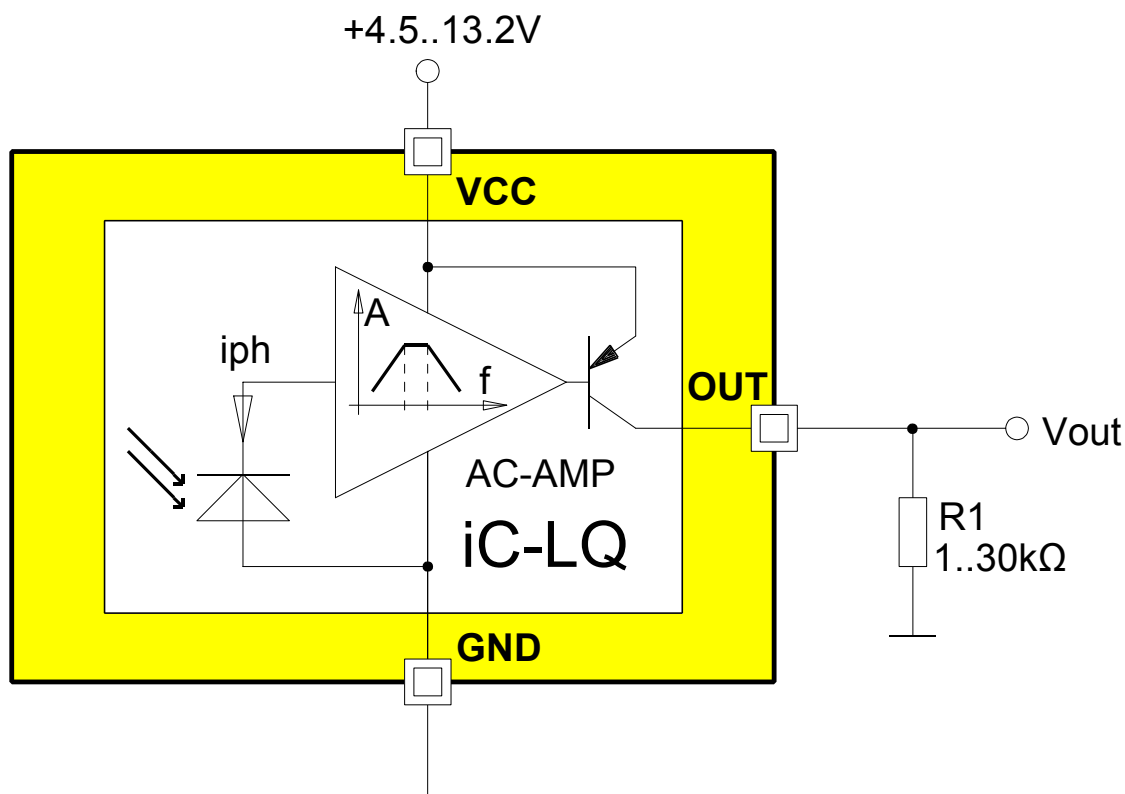

DESCRIPTION

iC-LQ is a sensor for pulse and alternating light with a monolithically integrated photodiode. The device supersedes conventional photoreceivers, such as those in light barriers, for example.

At the first stage sensitive changes in the photocurrent are amplified whereas the photocurrents caused by background light are electronically suppressed with over 60 dB (at 100 Hz). The integrated amplifier forms a band-pass characteristic without using any external components. The high pass suppresses ambient light and low frequency alternating light and the low pass reduces high frequency noise.

For visible light or near infrared the highest sensitivity for alternating light signals is reached at approximately 150 kHz; for pulse light this is reached at 1.2 μ s and upwards. The transimpedance amplification can be selected within a range of approximately 1 M Ω to 10 M Ω via the external operating load.

iC-LQ is available as a 4-pole TO18 metal can package with a glass lens or flat window and as an optoBGA™ package for surface mounting. Customized COB versions are also possible.

CHIP LAYOUT

PAD DESCRIPTION

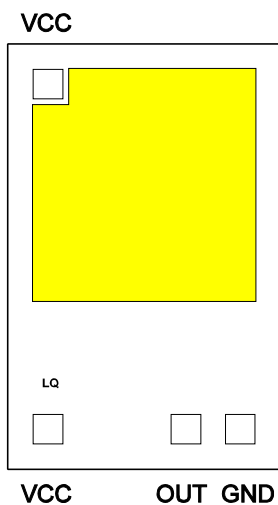

Name	Function
VCC	+4.5...13.2 V Supply Voltage
OUT	Current Output
GND	Ground

ABSOLUTE MAXIMUM RATINGS

Values beyond which damage may occur; device operation is not guaranteed.

Item	Symbol	Parameter	Conditions	Fig.	Limits		Unit
					Min.	Max.	
G001	VCC	Supply Voltage			0	15	V
G002	I(OUT)	Output Current			-4	4	mA
TG1	Tj	Junction Temperature			-40	150	°C
TG2	Ts	Storage Temperature	see package specifications				°C

THERMAL DATA

Operating Conditions: VCC = 4.5...13.2 V

Item	Symbol	Parameter	Conditions	Fig.	Limits			Unit
					Min.	Typ.	Max.	
T1	Ta	Operating Ambient Temperature Range	see package specifications					°C

All voltages are referenced to ground unless otherwise noted.

All currents into the device pins are positive; all currents out of the device pins are negative.

iC-LQ

PULSE AND AC LIGHT SENSOR



Rev B2, Page Page 4/7

ELECTRICAL and OPTICAL CHARACTERISTICS

Operating Conditions: VCC = 4.5...13.2 V, R1 = 10 kΩ, CL = 20 pF, λ = 875 nm, Tj = -25...125 °C, unless otherwise noted

Item	Symbol	Parameter	Conditions	Tj °C	Fig.				Unit
						Min.	Typ.	Max.	
Total Device									
001	VCC	Permissible Supply Voltage				4.5		13.2	V
002	I(VCC)	Supply Current	E(PD) = 0 E(PD)ac = 0, E(PD)pk = 0, E(PD)dc = 30 mW/cm ²			0.4	0.8	1.4	mA
								2	mA
003	Vs(OUT)	Output Saturation Voltage	Vs(OUT) = VCC - V(OUT); I() = -1 mA					0.5	V
004	I(OUT)	Permissible Output Current				-2		0	mA
005	I0(OUT)	Output Bias Current	E(PD) = 0 E(PD) = 0, VCC = 5 V	27		-235	-145	-105	μA μA
006	Vc()hi	Output Clamp Voltage hi	Vc()hi = V(OUT) - VCC; VCC = 0 V, I() = 4 mA			0.25	0.5	1.4	V
007	Vc()lo	Output Clamp Voltage lo	I() = -4 mA			-1.4	-0.5	-0.25	V
Photodiode									
008	Aph()	Radiant Sensitive Area				1			mm ²
009	S(λ)max	Spectral Sensitivity					0.5		A/W
010	λar	Spectral Application Range	Se(λar) = 0.1 × S(λ)max			500		1050	nm
Photocurrent Amplifier									
011	E()dc	Permissible DC Irradiance	λ _{LED} for S(λ)max, iC-LQ chip					30	mW/ cm ²
012	Ev()dc	Ambient Light Susceptibility	standard illuminant A, T = 2856 K TO18-4F TO18-4L TO18-4F TO18-4L				50 7 70 10		mW/ cm ² klx klx
013	E()pk	Permissible Peak Irradiance	I(OUT) increases or remains constant as E()pk increases; chip, TO18-4F TO18-4L					100 15	mW/ cm ²
014	ηpk	Pulse Light Amplification 875nm	VCC = 5 V, E(PD)pk = 35 μW/cm ² tr = tf = 0.1 μs, twpk = 1.2 μs; chip, TO18-4F TO18-4L			100 700	220 1540	350 2500	A/W A/W
015	ηpk	Pulse Light Amplification 850nm	see 014; chip, TO18-4F TO18-4L				250 1800		A/W A/W
016	Δt()	Output Current Delay	see 014, I(OUT): 0 → 50 % peak value					1.5	μs
017	trec	Recovery Time	see 014, settled better 10 % to initial quiescent point					15	μs
018	trec	Power Flash Recovery Time	E(PD)pk = 35 mW/cm ² , twpk = 100 μs					60	μs
019	ηac	AC Light Amplification	f = fc, E(PD)ac = 35 μWp/cm ² ; chip, TO18-4F TO18-4L				400 2800		A/W A/W
021	fc	Bandpass Center Frequency	R1 = 1 kΩ, CL = 20 pF R1 = 10 kΩ, CL = 20 pF				130 125		kHz kHz
022	fhc	Upper Cut-off Frequency (-3db)	R1 = 1 kΩ, CL = 20 pF R1 = 10 kΩ, CL = 20 pF				390 350		kHz kHz
023	flc	Lower Cut-off Frequency (-3db)	R1 = 1 kΩ, CL = 20 pF R1 = 10 kΩ, CL = 20 pF				45 45		kHz kHz
024	Q	Filter Q-Factor	Q = fc / (fhc - flc); R1 = 1 kΩ, CL = 20 pF R1 = 10 kΩ, CL = 20 pF				0.38 0.41		

ELECTRICAL and OPTICAL CHARACTERISTICS

Operating Conditions: VCC = 4.5...13.2 V, R1 = 10 kΩ, CL = 20 pF, λ = 875 nm, Tj = -25...125 °C, unless otherwise noted

Item	Symbol	Parameter	Conditions	Tj °C	Fig.				Unit
						Min.	Typ.	Max.	
025	G100	LF Suppression	f = 100 Hz				60		dB
026	Vn(OUT)	Output Noise Voltage (RMS)	VCC = 5 V, E(PD) = 0				7		mV
			VCC = 5 V, Ev(PD)dc ca. 15000 lx, standard illuminant A, T = 2856 K, chip				20		mV
027	ton(VCC)	Power-On Setup Time	Tj = -25...70 °C					450	μs

ELECTRICAL and OPTICAL CHARACTERISTICS: Diagrams

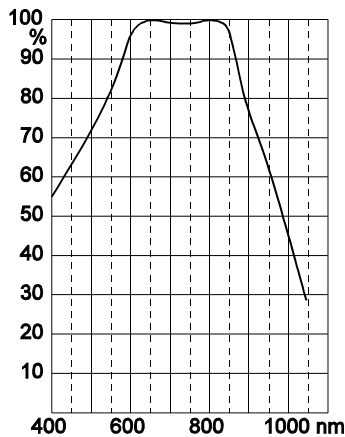

Fig. 1: typical relative spectral sensitivity

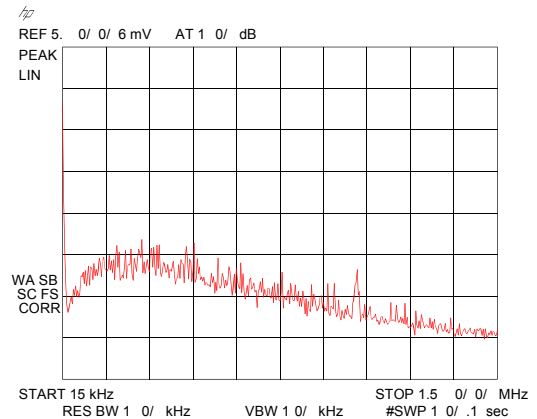

Fig. 3: output voltage noise [mV/√10 kHz] to 10 kΩ/20 pF load when Ev(dc) < 500 lx

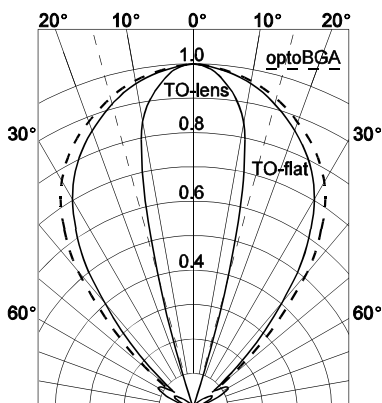

Fig. 2: typical directional characteristics for TO18 and optoBGA packages

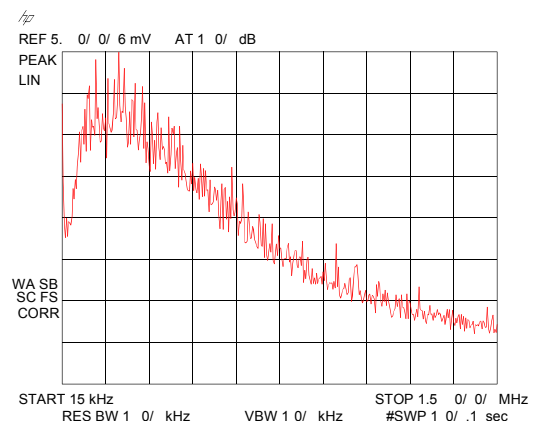

Fig. 4: output voltage noise [mV/√10 kHz] to 10 kΩ/20 pF load with Ev(dc) of approx. 15000 lx (standard illuminant A, T = 2856 K)

APPLICATION HINTS

Example Output Signals

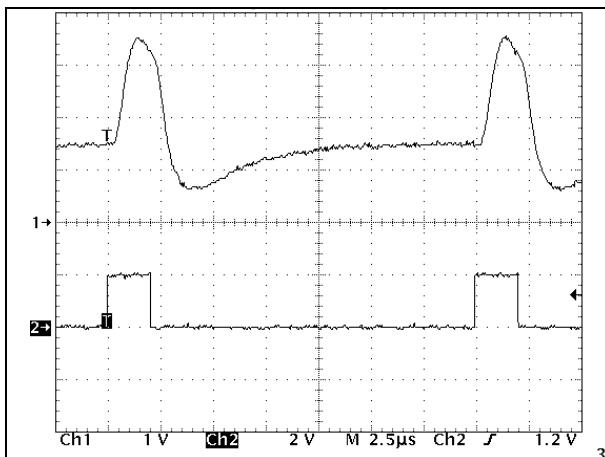

Fig. 5: output signal for 2 μ s pulse light.
Transmitter: LED 875 nm with $t_r = t_f = 0.1 \mu$ s;
VCC = 5 V, R1 = 10 k Ω , CL = 20 pF;
Chan 1: V(OUT), 1 V/DIV vertically,
Chan 2: I(LED), 20 mA/DIV vertically

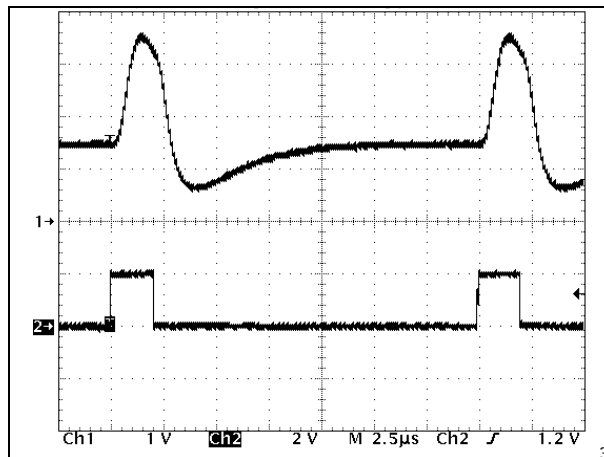

Fig. 6: output signal for 2 μ s pulse light with noise
(accumulated over 256 samples)

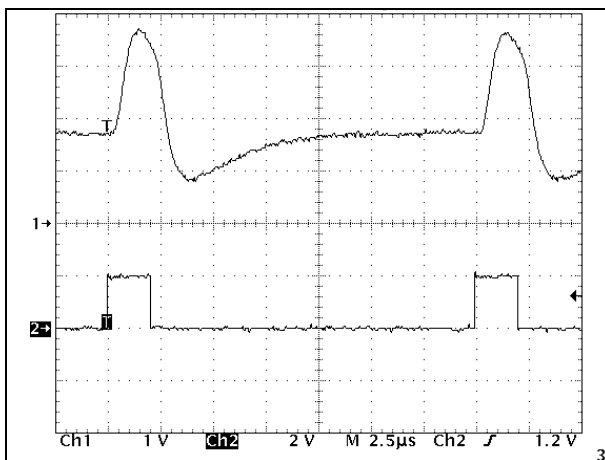

Fig. 7: output signal for 2 μ s pulse light, superimposed by ambient light of approx. 15000 Lux.

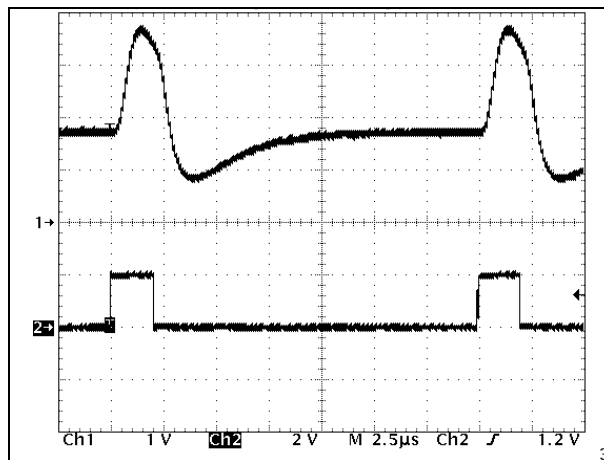

Fig. 8: as for Fig. 7, accumulated for visibility over 256 samples. Despite of bright ambient light condition noise remains low level.

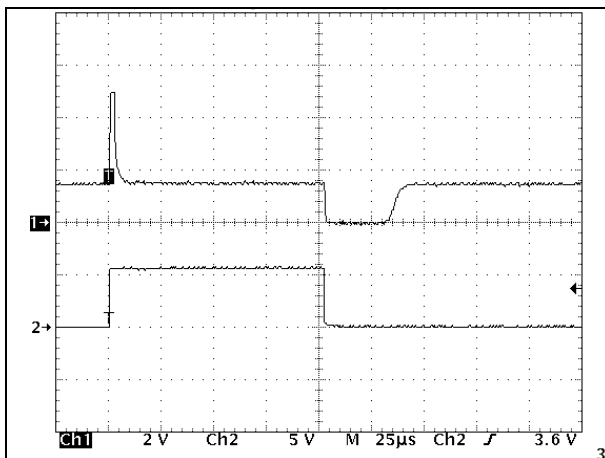

Fig. 9: recovery after 100 µs power pulse; back to ready-to-receive state after approx. 35 µs;
Chan 1: V(OUT), 2 V/DIV vertically

ORDERING INFORMATION

Type	Package	Order designation
iC-LQ	- TO18-4 lens TO18-4 flat window optoBGA™	iC-LQ chip iC-LQ TO18-4L iC-LQ TO18-4F iC-LQ oBGA LQ1C

For information about prices, terms of delivery, other package options, etc., please contact:

iC-Haus GmbH
Am Kuemmerling 18
D-55294 Bodenheim
GERMANY

Tel +49-6135-9292-0
Fax +49-6135-9292-192
<http://www.ichaus.com>

This specification is for a newly developed product. iC-Haus therefore reserves the right to modify data without further notice. Please contact us to ascertain the current data. The data specified is intended solely for the purpose of product description and is not to be deemed guaranteed in a legal sense. Any claims for damage against us - regardless of the legal basis - are excluded unless we are guilty of premeditation or gross negligence.

We do not assume any guarantee that the specified circuits or procedures are free of copyrights of third parties.

Copying - even as an excerpt - is only permitted with the approval of the publisher and precise reference to source.