

# iC-LSHB

## INCREMENTAL PHOTSENSOR ARRAY

preliminary



Rev B1, Page 1/8

### FEATURES

- ◆ Monolithic array of independent photosensors with excellent matching
- ◆ Compact photosensor size of 800  $\mu\text{m}$  x 330  $\mu\text{m}$  enabling smaller encoder systems
- ◆ Moderate track pitch for reasonable alignment tolerances
- ◆ Ultra low dark currents for operation to high temperature
- ◆ Low noise amplifiers with high transimpedance of typ. 4 M $\Omega$
- ◆ Short-circuit-proof, low impedance voltage outputs for enhanced EMI tolerance
- ◆ Space saving 15-pin optoBGA package (RoHS compatible)
- ◆ Low power consumption from single 4.5 V to 5.5 V supply
- ◆ Operational temperature range of -40 to 125  $^{\circ}\text{C}$
- ◆ Available options
  - reticle assembly, code discs
  - customized COB modules

### APPLICATIONS

- ◆ Incremental rotary encoders
- ◆ Linear scales

### PACKAGES

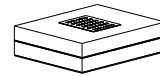

15-pin optoBGA  
6.2 mm x 5.2 mm

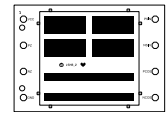

Chip  
2.88 mm x 2.04 mm

### BLOCK DIAGRAM

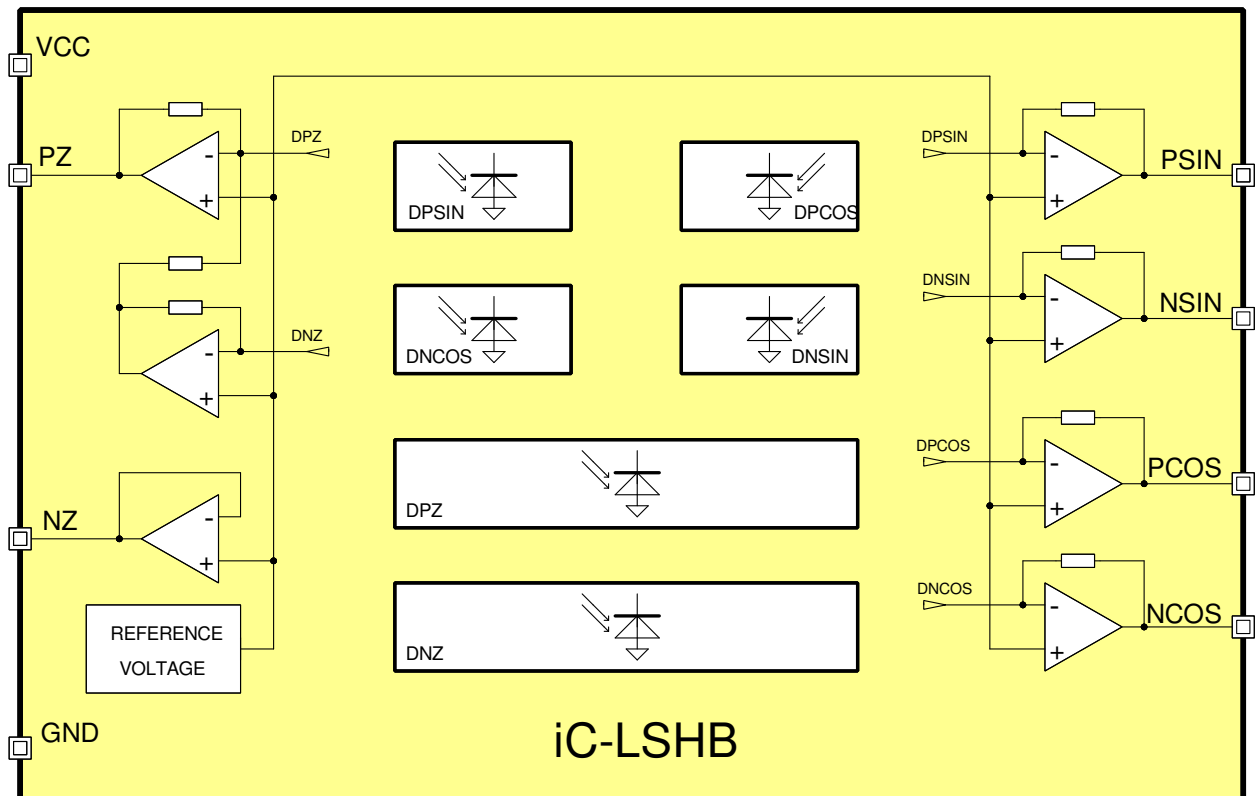

# iC-LSHB

## INCREMENTAL PHOTODIODE SENSOR ARRAY

preliminary



Rev B1, Page 2/8

### DESCRIPTION

iC-LSHB is an optical sensor IC with 6 integrated photodiodes whose signal currents are converted into output voltages by low-noise transimpedance amplifiers.

The IC is well suited for the operation of interpolation circuits for linear or rotary incremental encoders with an index signal. iC-LSHB thus has a shamrock-style sensor layout of four photodiodes, each with an active area of  $800\ \mu\text{m} \times 330\ \mu\text{m}$ . Both a positive and negative sine signal and a positive and negative cosine signal are generated from a single shared code track. The signal amplifier layout ensures excellent paired channel matching, reducing signal differences to an absolute minimum.

Two separate photodiodes, with active areas of  $1720\ \mu\text{m} \times 150\ \mu\text{m}$  apiece, are employed for the differential scanning of the index track and to generate the zero signal.

The spectral sensitivity ranges from visible to near

infrared light, with the maximum sensitivity close to a wavelength of 680 nm.

Due to a high transimpedance gain of typically  $4\ \text{M}\Omega$ , signal voltages of several hundred millivolts are obtained at low illumination levels. An output signal amplitude of 1 V is typical in low light conditions, for instance when iC-LSHB is illuminated at only  $0.2\ \text{mW}/\text{cm}^2$  by a 740 nm LED.

A threefold intensity is sufficient when using iC-LSHB for encoder applications with typical disc and mask codes. Therefore, a relatively low LED current is enough to operate the sensor, proving beneficial to the life expectancy of the LED at high operating temperatures.

iC-LSHB is suitable for on-chip or LED-end mounting of the grating (reticle), so that the period count, signal waveform, phase shift and index marker code can be selected with flexibility.

### PACKAGES

#### PAD LAYOUT (2.88 mm x 2.04 mm)

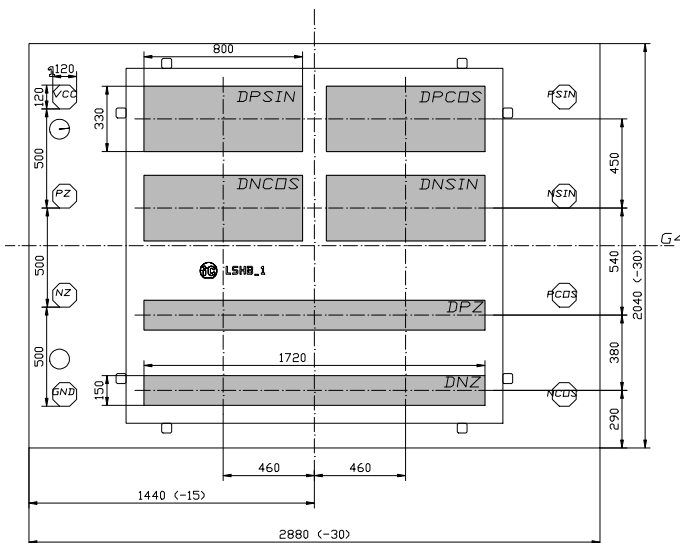

#### PAD FUNCTIONS

##### No. Name Function

- |   |      |                            |
|---|------|----------------------------|
| 1 | VCC  | +4.5..5.5 V Supply Voltage |
| 2 | PZ   | Zero Signal (Index)        |
| 3 | NZ   | Reference Voltage Output   |
| 4 | GND  | Ground                     |
| 5 | NCOS | Cosine -                   |
| 6 | PCOS | Cosine +                   |
| 7 | NSIN | Sine -                     |
| 8 | PSIN | Sine +                     |

Notes: All outputs supply analog voltages.

Dimension G4 is the reference radius of the chip center.

# iC-LSHB

## INCREMENTAL PHOTSENSOR ARRAY

preliminary



Rev B1, Page 3/8

### PIN CONFIGURATION

oBGA LSH2C (6.2 mm x 5.2 mm)

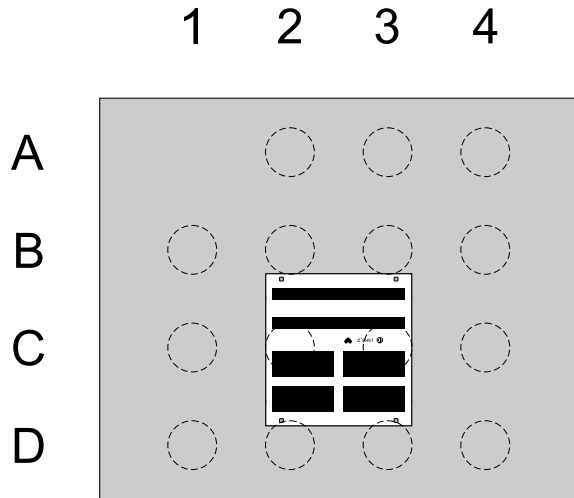

LSH2C\_LSHB2\_PIN-BELEGUNG

### PIN FUNCTIONS

No. Name Function

A2

A3

A4

B1

B2

B3

B4

C1 NCOS Cosine -

C2 PCOS Cosine +

C3 NZ Reference Voltage Output

C4 GND Ground

D1 NSIN Sine -

D2 PSIN Sine +

D3 VCC +4.5..5.5 V Supply Voltage

D4 PZ Zero Signal (Index)

# iC-LSHB

## INCREMENTAL PHOTODIODE ARRAY

preliminary



Rev B1, Page 4/8

### ABSOLUTE MAXIMUM RATINGS

These ratings do not imply operating conditions; functional operation is not guaranteed. Beyond these ratings device damage may occur.

Item No.	Symbol	Parameter	Conditions	Limits		Unit
				Min.	Max.	
G001	VCC	Voltage at VCC		-0.3	6	V
G002	I(VCC)	Current in VCC		-20	20	mA
G003	V()	Pin Voltage, all signal outputs		-0.3	VCC + 0.3	V
G004	I()	Pin Current, all signal outputs		-20	20	mA
G005	Vd()	ESD Susceptibility, all pins	HBM, 100 pF discharged through 1.5 kΩ		2	kV
G006	Tj	Junction Temperature		-40	150	°C
G007	Ts	Chip Storage Temperature		-40	150	°C

### THERMAL DATA

Item No.	Symbol	Parameter	Conditions	Min.	Typ.	Max.	Unit
T01	Ta	Operating Ambient Temperature Range	package oBGA LSH2C	-40		125	°C
T02	Ts	Storage Temperature Range	package oBGA LSH2C	-40		125	°C
T03	Tpk	Soldering Peak Temperature	package oBGA LSH2C  tpk < 20 s, convection reflow tpk < 20 s, vapor phase soldering  TOL (time on label) 8 h; Please refer to customer information file No. 7 for details.			245 230	°C °C

All voltages are referenced to ground unless otherwise stated.

All currents flowing into the device pins are positive; all currents flowing out of the device pins are negative.

# iC-LSHB

## INCREMENTAL PHOTSENSOR ARRAY



Rev B1, Page 5/8

### ELECTRICAL CHARACTERISTICS

Operating conditions: VCC = 4.5..5.5 V, Tj = -40..125 °C, unless otherwise stated

Item No.	Symbol	Parameter	Conditions				Unit
				Min.	Typ.	Max.	
<b>Total Device</b>							
001	VCC	Permissible Supply Voltage		4.5		5.5	V
002	I(VCC)	Supply Current in VCC	no output load, photocurrents within linear operating range (no override)		6.5	12	mA
003	Vc()hi	Clamp-Voltage hi at all pins	I() = 4 mA			11	V
004	Vc()lo	Clamp-Voltage lo at all pins	I() = -4 mA	-1.2		-0.3	V
<b>Photosensors</b>							
101	$\lambda_{ar}$	Spectral Application Range	$Se(\lambda_{ar}) = 0.25 \times S(\lambda)_{max}$	400		950	nm
102	$\lambda_{pk}$	Peak Sensitivity Wavelength			680		nm
103	Aph()	Radiant Sensitive Area of DPSIN, DPCOS, DNSIN, DNCOS	0.8 mm x 0.33 mm		0.264		mm <sup>2</sup>
104	Aph()	Radiant Sensitive Area of DPZ, DNZ	1.72 mm x 0.15 mm		0.258		mm <sup>2</sup>
105	$S(\lambda_r)$	Spectral Sensitivity	$\lambda_{LED} = 740 \text{ nm}$		0.5		A/W
106	$S(\lambda)_{max}$	Maximum Spectral Sensitivity	$\lambda_r = \lambda_{pk}$		0.55		A/W
107	E()mx	Irradiance For Maximum Signal Level	$\lambda_{LED} = 740 \text{ nm}$ , Vout() not yet saturated	0.15	0.5	0.8	mW/cm <sup>2</sup>
<b>Photocurrent Amplifiers</b>							
201	Iph()	Permissible Photocurrent Operating Range		0		280	nA
202	$\eta()r$	Photo Sensitivity (light-to-voltage conversion ratio)	$\lambda_{LED} = 740 \text{ nm}$	0.8	1.2	2.0	V/ $\mu$ W
203	Z()	Equivalent Transimpedance Gain	$Z = Vout() / Iph()$	2.69	4.0	5.46	M $\Omega$
204	TCz	Temperature Coefficient of Transimpedance Gain			-0.12		%/°C
209	$\Delta Z()pn$	Transimpedance Gain Matching Of Paired Amplifiers	P.. channel vs. corresponding N.. channel	-0.2		0.2	%
210	$\Delta Vout()pn$	Signal Matching	no illumination, any output vs. any output	-35		35	mV
211	$\Delta Vout()pn$	Signal Matching	no illumination, P.. output vs. corresponding N.. output	-2.5		2.5	mV
212	fc()hi	Cut-off Frequency (-3 dB)		120	180	280	kHz
213	VNoise()	RMS Output Noise	illuminated to 500 mV signal level above dark level, 500 kHz band width		0.5		mV
<b>Signal Outputs PSIN, NSIN, PCOS, NCOS, PZ</b>							
301	Vout()mx	Permissible Maximum Output Voltage	illumination to E()mxr, linear gain	2.45	2.72	3.02	V
302	Vout()d	Dark Signal Level	no illumination, load 20 k $\Omega$ vs. +2 V	600	770	1000	mV
303	Vout()acmx	Maximum Signal Level	$Vout()acmx = Vout()mx - Vout()d$	1.48	1.96	2.35	V
304	Isc()hi	Short-circuit Current hi	load current to ground	100	420	800	$\mu$ A
305	Isc()lo	Short-circuit Current lo	load current to IC	250	480	700	$\mu$ A
306	Ri()	Internal Output Resistance	f = 1 kHz	70	110	180	$\Omega$
<b>Reference Voltage NZ</b>							
401	VREF	Reference Voltage	I(VREF) = 0...+1.6 mA	600	770	1000	mV
402	dVout()	Load Balancing	I(VREF) = 0...+1.6 mA	-10		+10	mV
403	Isc()hi	Short-circuit Current hi	load current to ground	200	420	800	$\mu$ A
404	Isc()lo	Short-circuit Current lo	load current to IC	2	4.5	10	mA

### APPLICATION HINTS

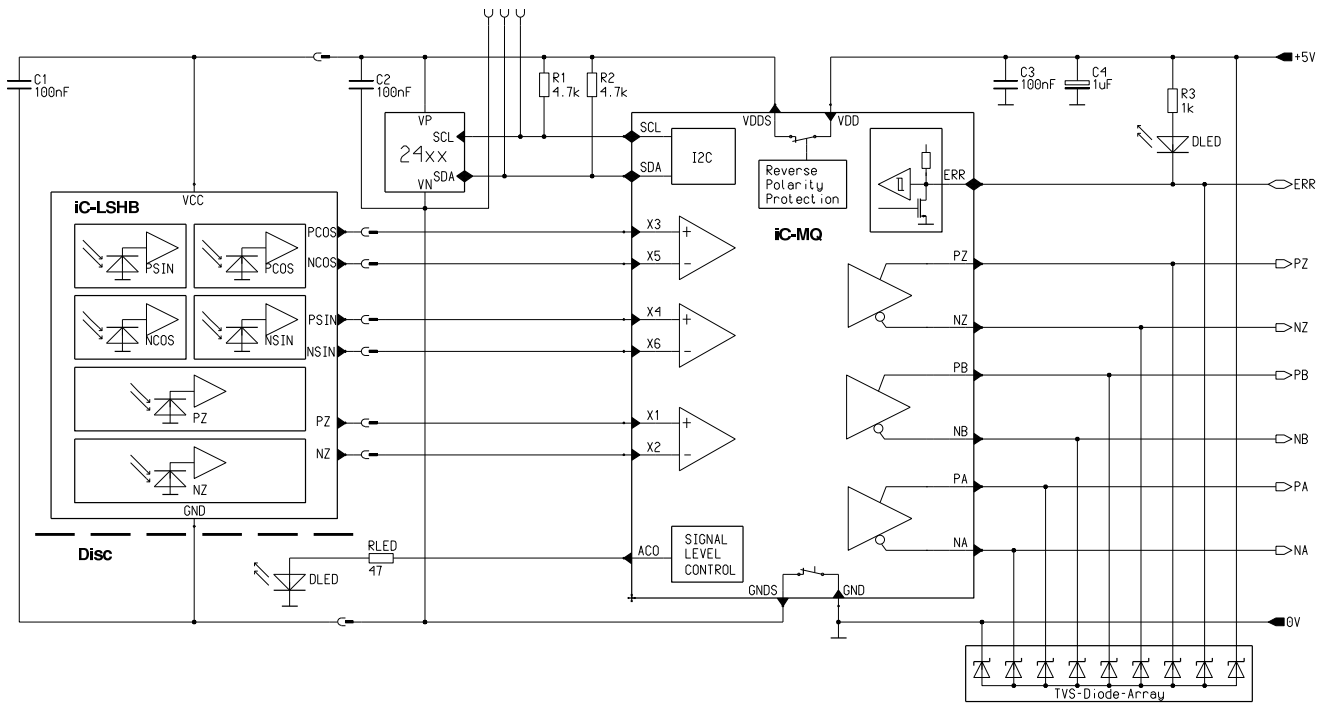

Figure 1: Example of incremental encoder with RS422 output

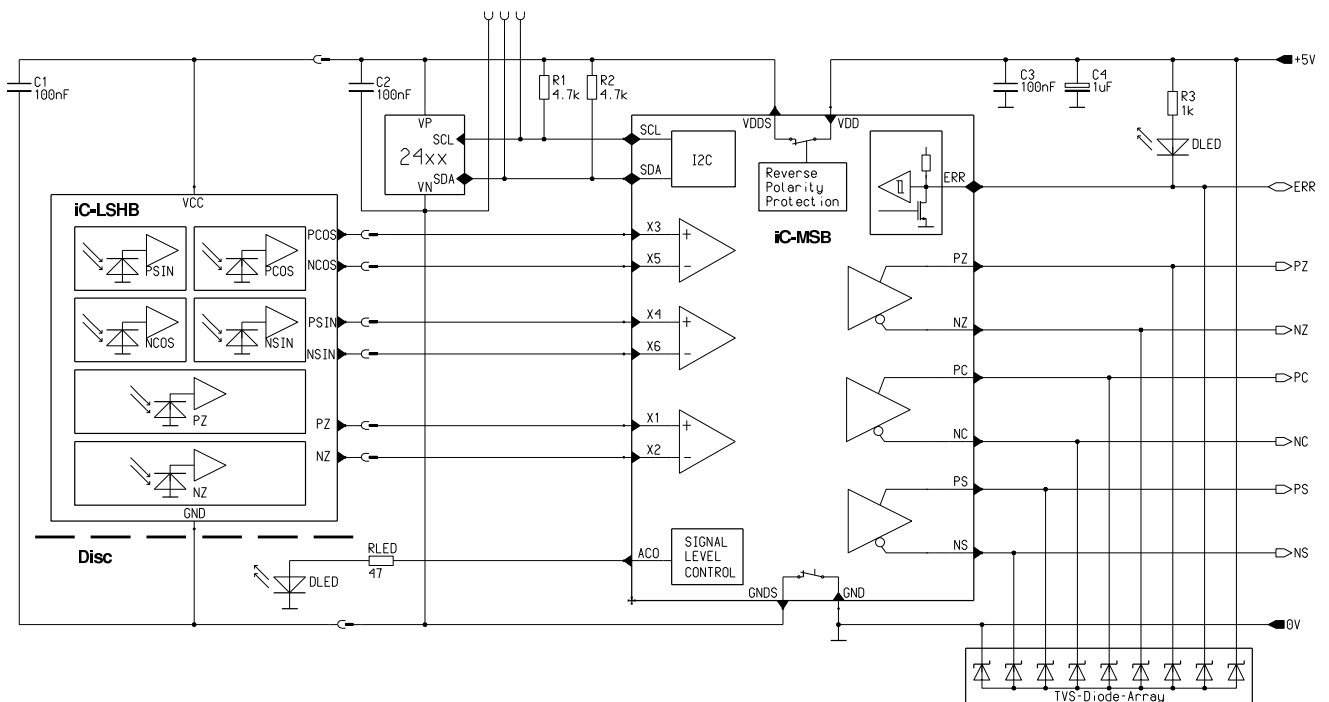

Figure 2: Example of sine encoder with 1 Vpp output

# iC-LSHB

## INCREMENTAL PHOTODIODE ARRAY

preliminary



Rev B1, Page 7/8

iC-Haus expressly reserves the right to change its products and/or specifications. An Infoletter gives details as to any amendments and additions made to the relevant current specifications on our internet website [www.ichaus.de/infoletter](http://www.ichaus.de/infoletter); this letter is generated automatically and shall be sent to registered users by email.

Copying – even as an excerpt – is only permitted with iC-Haus approval in writing and precise reference to source.

iC-Haus does not warrant the accuracy, completeness or timeliness of the specification on this site and does not assume liability for any errors or omissions in the materials. The data specified is intended solely for the purpose of product description. No representations or warranties, either express or implied, of merchantability, fitness for a particular purpose or of any other nature are made hereunder with respect to information/specification or the products to which information refers and no guarantee with respect to compliance to the intended use is given. In particular, this also applies to the stated possible applications or areas of applications of the product.

iC-Haus conveys no patent, copyright, mask work right or other trade mark right to this product. iC-Haus assumes no liability for any patent and/or other trade mark rights of a third party resulting from processing or handling of the product and/or any other use of the product.

As a general rule our developments, IPs, principle circuitry and range of Integrated Circuits are suitable and specifically designed for appropriate use in technical applications, such as in devices, systems and any kind of technical equipment, in so far as they do not infringe existing patent rights. In principle the range of use is limitless in a technical sense and refers to the products listed in the inventory of goods compiled for the 2008 and following export trade statistics issued annually by the Bureau of Statistics in Wiesbaden, for example, or to any product in the product catalogue published for the 2007 and following exhibitions in Hanover (Hannover-Messe).

We understand suitable application of our published designs to be state-of-the-art technology which can no longer be classed as inventive under the stipulations of patent law. Our explicit application notes are to be treated only as mere examples of the many possible and extremely advantageous uses our products can be put to.

# iC-LSHB

## INCREMENTAL PHOTODSENSOR ARRAY

preliminary



Rev B1, Page 8/8

### ORDERING INFORMATION

Type	Package	Options	Order Designation
iC-LSHB	optoBGA 6.2 mm x 5.2 mm optoBGA 6.2 mm x 5.2 mm optoBGA 6.2 mm x 5.2 mm	- - reticle 42-1024 reticle 42-4096  Code Disc 1024 PPR, OD/ID $\varnothing$ 42/18 mm, glass  Code Disc 4096 PPR, OD/ID $\varnothing$ 42/18 mm, glass	iC-LSHB chip iC-LSHB OBGA LSH2C iC-LSHB OBGA LSH2C-2R iC-LSHB OBGA LSH2C-4R  LSHB2S 42-1024  LSHB4S 42-4096

For technical support, information about prices and terms of delivery please contact:

**iC-Haus GmbH**  
Am Kuemmerling 18  
D-55294 Bodenheim  
GERMANY

**Tel.: +49 (61 35) 92 92-0**  
**Fax: +49 (61 35) 92 92-192**  
**Web: <http://www.ichaus.com>**  
**E-Mail: [sales@ichaus.com](mailto:sales@ichaus.com)**

Appointed local distributors: [http://www.ichaus.com/sales\\_partners](http://www.ichaus.com/sales_partners)