

# iC-HG EVAL HG20M

HIGH-SPEED MODULE FOR SMD VCSEL ARRAYS

preliminary



Rev A3, Page 1/3

## ORDERING INFORMATION

Type	Package	Options	Order Designation
iC-HG	HG20M (DIL28)	-	iC-HG iCSY HG20M

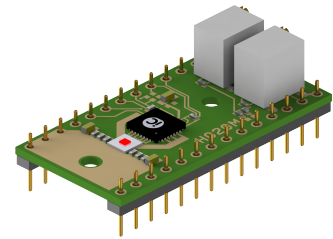

Figure 1: HG20M Package (DIL28)

## PIN CONFIGURATION

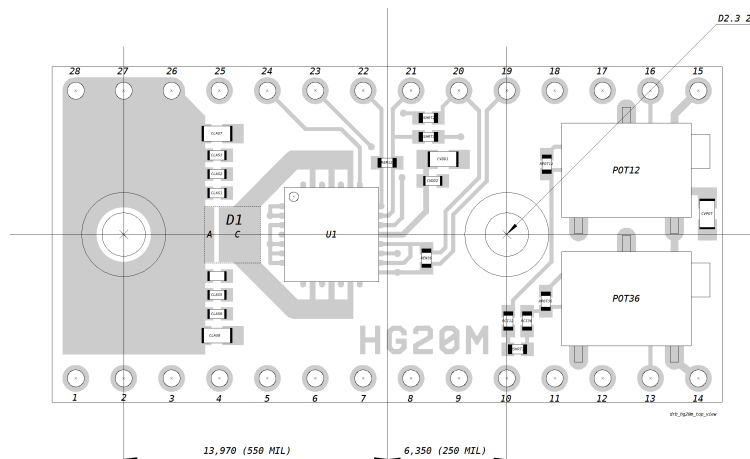

Figure 2: Top view / Dimensions in mm

No	Name	Function	No	Name	Function
1	GND	Ground, Analog Ground	15	POTVDD	Potentiometer 12 36 VDD
2	GND	Ground, Analog Ground	16	RCI12	Current Control Voltage 12
3	GND	Ground, Analog Ground	17	POTGND	Potentiometer 12 36 GND
4	GND	Ground, Analog Ground	18	POTGND	Potentiometer 12 36 GND
5	nc	not connected	19	EN46	Input Channel 4 + 6
6	nc	not connected	20	EN35	Input Channel 3 + 5
7	nc	not connected	21	EN2	Input Channel 2
8	nc	not connected	22	EN1	Input Channel 1
9	nc	not connected	23	ELVDS	TTL/LVDS Input Selector
10	nc	not connected	24	NER	Error Monitor Output
11	nc	not connected	25	VDD	Supply Voltage
12	nc	not connected	26	LDA	Anode Laser Diode
13	RCI36	Current Control Voltage 36	27	LDA	Anode Laser Diode
14	POTVDD	Potentiometer 12 36 VDD	28	LDA	Anode Laser Diode

### SMT POSITIONS

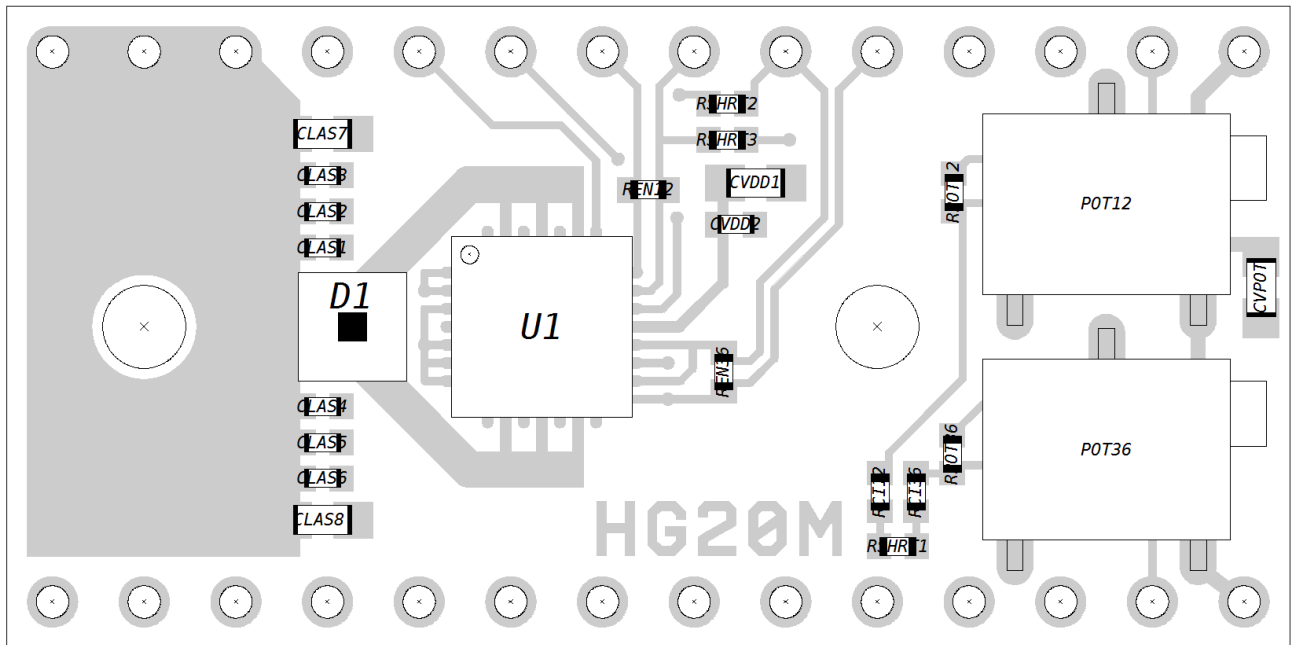
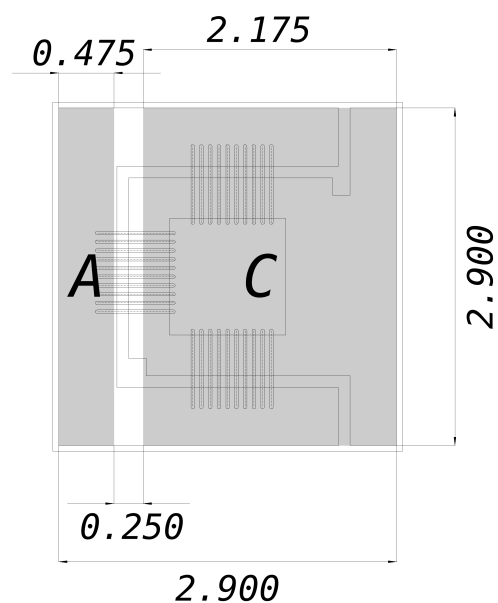

Figure 3: SMT Positions

**NOTE:** Module must be baked before exposing to high temperature processes (e.g. reflow soldering) to avoid delamination, PCB/VIA damages and popcorning (min 24 h at 100 °C). The PCB has a very low thermal resistance that makes manual soldering of SMT devices difficult.



All Dimensions are in mm

019\_PCB\_E30

Figure 4: Details of VCSEL pad

# iC-HG EVAL HG20M

HIGH-SPEED MODULE FOR SMD VCSEL ARRAYS

preliminary



Rev A3, Page 3/3

## SCHEMATICS

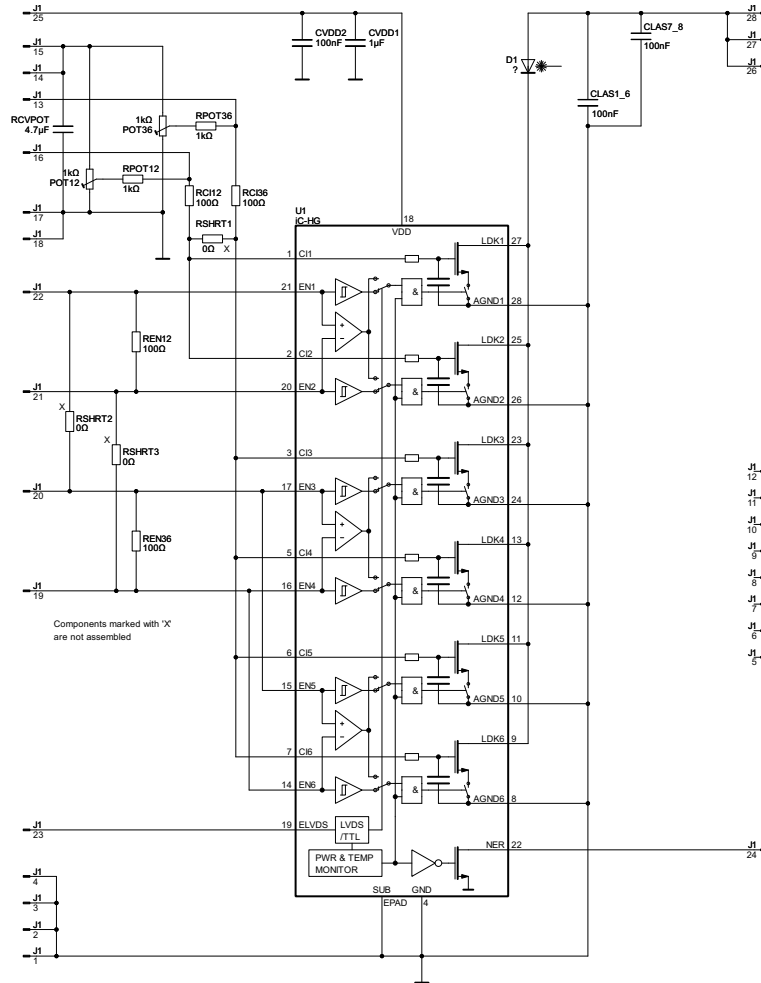

Figure 5: Circuit diagram

## ABSOLUTE MAXIMUM RATINGS

Item No.	Symbol	Parameter	Conditions	Min.	Typ.	Max.	Unit
TG1	Ta	Operating Ambient Temperature Range		-20		85	°C
TG2	Ts	Storage Temperature Range		-20		85	°C

iC-Haus expressly reserves the right to change its products and/or specifications. An info letter gives details as to any amendments and additions made to the relevant current specifications on our internet website [www.ichaus.com/infoletter](http://www.ichaus.com/infoletter); this letter is generated automatically and shall be sent to registered users by email.

Copying – even as an excerpt – is only permitted with iC-Haus' approval in writing and precise reference to source.

iC-Haus does not warrant the accuracy, completeness or timeliness of the specification and does not assume liability for any errors or omissions in these materials.

The data specified is intended solely for the purpose of product description. No representations or warranties, either express or implied, of merchantability, fitness for a particular purpose or of any other nature are made hereunder with respect to information/specification or the products to which information refers and no guarantee with respect to compliance to the intended use is given. In particular, this also applies to the stated possible applications or areas of applications of the product.

iC-Haus products are not designed for and must not be used in connection with any applications where the failure of such products would reasonably be expected to result in significant personal injury or death (*Safety-Critical Applications*) without iC-Haus' specific written consent. Safety-Critical Applications include, without limitation, life support devices and systems. iC-Haus products are not designed nor intended for use in military or aerospace applications or environments or in automotive applications unless specifically designated for such use by iC-Haus.

iC-Haus conveys no patent, copyright, mask work right or other trade mark right to this product. iC-Haus assumes no liability for any patent and/or other trade mark rights of a third party resulting from processing or handling of the product and/or any other use of the product.