

Digital sensor output - PNP/NPN/PP or IO-Link?

By David Lin, Uwe Malzahn and Álvaro Pineda García

IN THE DEVELOPMENT of sensors with digital switching outputs or communication interfaces for parameterization it has become necessary to provide a wide range of system variations for world-wide use. In Europe with its traditional 24V digital output a PNP output is usually required, whereas on the American and Asian markets the NPN version is more common. Where specific to their country of use, other customers prefer the push-pull output

Dr. David Lin and Dipl.-Ing. Uwe Malzahn are Product Managers at iC-Haus GmbH, Bodenheim/Germany - www.ichaus.de

Dipl.-Ing. Álvaro Pineda García is Development Manager and CEO of Integrated Circuits Málaga - www.ic-malaga.com

(PP). Depending on the application, different source or drain currents are also mandatory. Globally active sensor manufacturers find themselves having to supply a large number of different models, resulting in high costs for development, storage, and logistics. In Europe the trend is gravitating towards a universal, bidirectional I/O connection, such as IO-Link. If, and when this trend will spread to the rest of the world and also become standard for cost-critical sensors at present remains to be seen. As is often the case, the range of applications is so broad that all customer requirements cannot be satisfied with one single standard. The following article suggests alternatives, with which development and logistics costs can be kept in line with low manufacturing costs and programmable solutions.

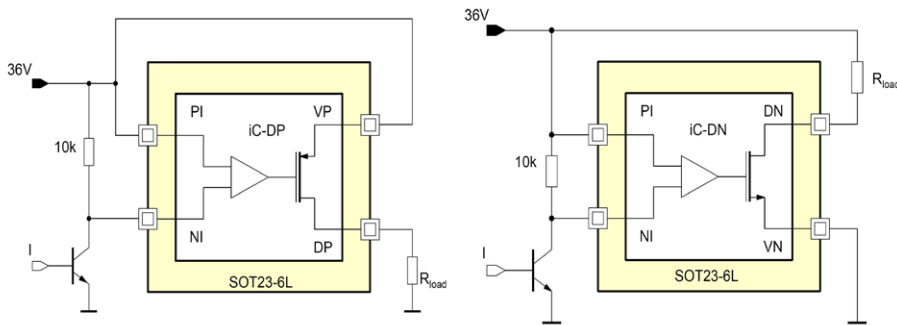

Fig. 1: Example PNP and NPN output stages.

Flexibility required

The diversity of digital sensor output variations creates a considerable amount of extra effort for development, stockkeeping, and sales. This in turn takes up development capacities, generates more documentation, binds capital for additional storage, complicates the logistics, and creates follow-up costs for repairs and service for the end customer. The higher development costs are caused by the additional engineering time and production preparation needed for each further variant, such as having to design a second PCB layout complete with tool costs and documentation. A flexible solution would be ideal here, which automatically configures itself in the end application or is set by the manufacturer on delivery. This flexibility usually has its price, included in the manufacturing costs, and is often over dimensioned so that it cannot be implemented in markets dominated by cost pressure. One approach would be to segment the sensor applications so that the most cost-effective solution could be developed for each segment.

PNP and NPN output with a universal PCB layout

A discrete transistor is normally used for sensors with a simple PNP or NPN output. If additional protection against short-circuiting is required, this solution becomes too expensive and too unstable, and takes up too much space. In cases such as these, integrated PNP or NPN drivers can be deployed, as shown by devices iC-DP and iC-DN in figure 1. They supply a 200mA drain or source current at voltages of 4 to 36V and are short-circuit-proof in that they shutdown in the event of overtemperature. An integrated flyback diode permits operation of inductive loads. The 6-pin SOT23 package takes up just approximately 3x3mm of board space and enables input circuits with independent reference potentials to be applied. The pinout has been designed so that a universal, com-

mon PCB layout can be used for both the PNP and NPN options.

Figure 2 show an example layout for both solutions in SOT23-6L packages. The iC-DP package is turned through 180° and arranged so that the driver output pins DP and DN are at the output of the PCB. The SC59-3L package with just three pins, which is available as an option, also permits this pinout.

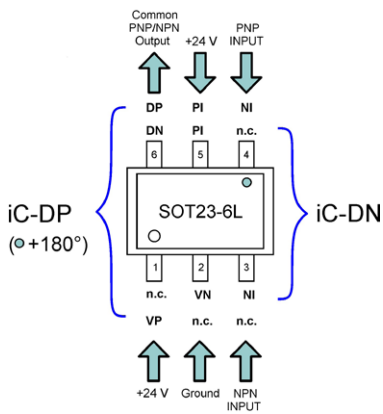

Fig. 2: PCB layout for PNP and NPN outputs.

Four output options with two inputs

If greater flexibility of the output options is required, such as an extra push-pull (PP), other integrated solutions must be found. Low manufacturing costs and minimum space requirements are in the lower end of the sensor market of prime importance, thus as many discrete elements as possible

must be integrated.

Figure 3 illustrates a solution for small sensor systems, where this objective has been pursued. In order to reduce system costs even further, the sensor system voltage supply has been integrated in the device. From an input voltage of 8 to 30V a linear regulator provides a 5V voltage with a 10mA current supply. A reverse polarity protection circuit, flyback diodes, and a temperature monitor have also been included. The short-circuit-proof output can be activated as a PNP, NPN, PP, or tristate output using the two inputs. In normal operation the driver supplies output currents of up to 150mA. In the event of an output short the current is limited to below 450mA. Measuring 2x2mm, the DFN package is also suitable for very compact sensors with a small diameter.

For parameterization in production or in the automation application, or for short-circuit monitoring by the microcontroller in the sensor, the similar iC-DXC device has an additional feedback communication channel. It compares the level at the output with the input logic level. If this is deviated from, for example through an output short, an interrupt signal is generated. Slightly larger than iC-DX in a 3x3mm DFN8 package, it has an extended driver capability of 200mA and is also limited to 450mA if it is shorted. The IO-Link specification is also supported.

IO-Link for parameterization using a field bus

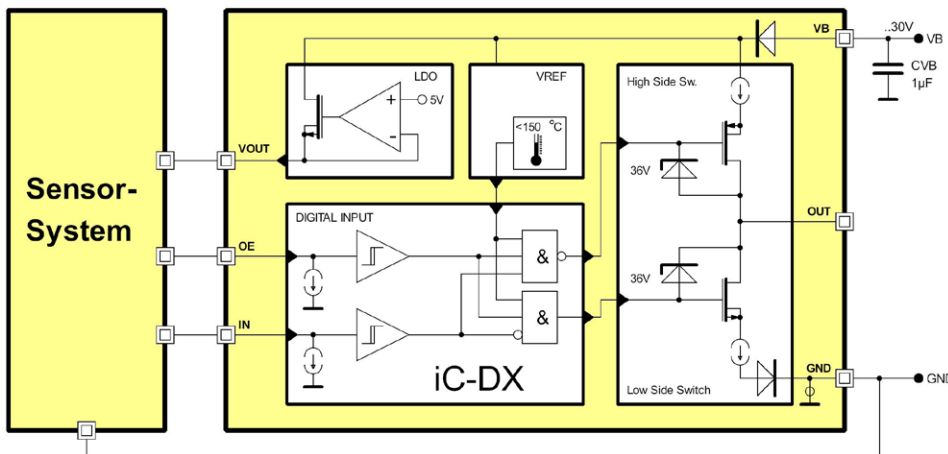

Fig. 3: Programmable driver for a PNP/NPN and PP output with a current supply.

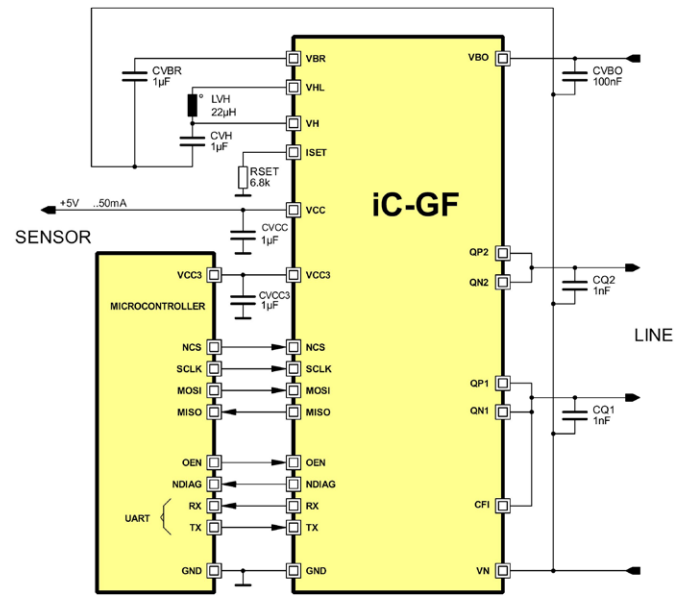

Fig. 4: Full IO-Link connection to field buses.

With complex sensors which require a full feedback channel for parameterization, for instance, the IO-Link solution is a good choice. It permits connection to the field bus level for communication with a central controller or PLC. At the same time it is also possible to calibrate the device during production, in the test lab, or during repairs using a clearly defined interface. Time-consuming individual development is then no longer required; existing software implementations for various microprocessors are also readily available. Figure 4 is a block diagram of the IO-Link solution with integrated transceiver iC-GF. It contains the full hardware interface for the sensor system with an integrated DC/DC converter. From an input voltage of 9 to 30V with a 22µH coil measuring just 2x2mm, this generates an intermediate circuit voltage of approximately 7V. With this and using two linear regulators, a 5V and a 3.3V supply voltage are provided for the microprocessor and sensor electronics. This permits a very low residual ripple, which is ideal for precision analog circuits. The total current carrying capacity of the converter is 50 mA. At the back end two driver stages of up to 150mA are available. These can also be connected in parallel and are short-circuit-proof.

Communication with the microcontroller is made through the SPI interface. In IO-Link the feedback channel with the CFI input is responsible for establishing communication with the sensor. To this end, a short current of at least 500mA is generated by the IO-Link master on the data line. It detects this short-circuit and informs the microcontroller with an interrupt. This in turn switches the outputs to tristate mode and awaits the message through the agreed IO-Link protocol. Data exchange for parameterization by the host computer can take place at a data rate of up to 230kbaud (COM3). The supply voltage and chip temperature is also monitored to prevent faulty operation in the event of undervoltage or destruction through overload. A reverse polarity protection circuit also safeguards the sensor system against destruction during installation.